

# Manual

## Simrad RD68 Fixed DSC VHF Radio

 [RETURN TO RD68 SERVICE MANUAL](#)

© 2000 Simrad Navico Ltd

The technical data, information and illustrations contained in this publication were to the best of our knowledge correct at the time of going to print. We reserve the right to change specifications, equipment, installation and maintenance instructions without notice as part of our policy of continuous development and improvement.

No part of this publication may be reproduced, stored in a retrieval system or transmitted in any form, electronic or otherwise without prior permission from Simrad Navico Ltd.

No liability can be accepted for any inaccuracies or omissions in the publication, although every care has been taken to make it as complete and accurate as possible.

# CONTENTS

## 1. GENERAL

1.1	Introduction .....	4
1.2	Licensing .....	5
1.3	Entering MMSI numbers .....	6

## 2. MAIN FUNCTIONS

2.1	General .....	8
2.2	Rotary controls .....	8
2.3	Backlighting .....	9
2.4	Changing channel .....	9
	2.4.1 Standard International channel .....	9
	2.4.2 Auxiliary & Private channels .....	10
2.5	Transmit power .....	11
2.6	Making a DSC call .....	11
2.7	Sending a Distress Alert call .....	14
2.8	Receiving a DSC call .....	16
2.9	Dual Watch .....	17
2.10	Tri Watch .....	18
2.11	Scan Mode .....	19
	2.11.1 Inhibit / enable channel from scan .....	19
2.12	Memory scan .....	20
	2.12.1 Add / remove memory scan channels .....	21
2.13	Priority channel & user channel select .....	22
	2.13.1 Programming user channel .....	22
2.14	Viewing call log .....	23

## 3. MISCELLANEOUS FUNCTIONS

3.1	Adjusting LCD contrast .....	24
3.2	Entering manual position & time .....	25
3.3	Entering local time .....	27
3.4	Viewing the directory .....	28
	3.4.1 Adding entry to directory .....	29
	3.4.2 Editing / deleting entry .....	30
3.5	Disabling key beep .....	32
3.6	Second channel mode .....	33
3.7	Speaker mute (handset models only) .....	33

## 4. INSTALLATION

4.1	VHF installation .....	34
4.2	Antenna installation recommendations .....	37
4.3	Electrical interference suppression .....	39

## 5. APPENDIX

5.1	Operating procedures .....	40
5.2	Transmission range .....	42
5.3	Frequency of channels .....	43
5.4	Fault finding .....	44
5.5	Optional accessories .....	45
5.6	Technical specification .....	46
5.7	Dimensions .....	47
5.8	Service & warranty .....	48

# 1 GENERAL

## 1.1 Introduction

The RD68 is a combined VHF radio and Class D Digital Selective Calling (DSC) unit. It supports the latest GMDSS requirements for non-SOLAS vessels from the International Maritime Organisation (IMO). It will enable you to make digitally selected calls, which are quicker and simpler to make than traditional voice calls using Channel 16. Should a distress situation occur, with the RD68 you can quickly raise an alert, indicating your identity, your position and automatically establish distress communication on the emergency voice channel.

The RD68 is robustly constructed using a pressure die cast aluminium case for effective heat dissipation, ensuring maximum transmission performance even after many hours constant use.

### Thank you for choosing Simrad

If you are pleased with your VHF we hope you will be interested in our range of marine electronic equipment, which is manufactured to the same high standards as the RD68. Please contact your nearest Simrad Agent for a catalogue showing our increasing range of high tech navigational instruments, GPS, autopilots, Radar, Fishfinders and VHF radio sets.

Simrad operate a policy of continual development and reserve the right to alter and improve the specification of their products without notice.



*Fig 1.1 - RD68 Combined VHF & DSC*

## 1.2 Licensing

### NOTE

**Prior to use check the national licensing requirements for the operator.**

In the UK license applications and queries should be made to the following authority -

Ship Radio Licensing  
Radio Licensing Centre  
The Post Office  
PO Box 1495  
Bristol  
BS99 3QS

A set may only be operated by, or under the supervision of a holder of a Certificate of Competence and Authority to Operate. This involves a simple examination and an annual license renewal fee. The VHF only certificate is administered by the Royal Yachting Association -

Royal Yachting Association  
RYA House  
Romsey Road  
Eastleigh  
Hants, SO5 4YA

Holders of the Restricted Certificate of Competence in Radio-telephony (which covers MF/HF SSB etc), do not need a separate VHF certificate.

In all other countries, please contact your regional authority for information.

## 1.3 Entering MMSI numbers

At the time of issue of your vessel's radio license, an MMSI (Maritime Mobile Service Identifier) must be requested. This is a nine digit number which must be permanently entered into the RD68, otherwise the DSC functions cannot be accessed.

### NOTE

If the boat or the RD68 are subsequently sold, the radio must be returned to an authorised Simrad agent for the MMSI number to be erased and the new owner's MMSI number entered.

For European leisure vessels fitted with VHF DSC equipment, a CEPT Short Range Certificate is required by the operator. Additional requirements, such as GOC or ROC may apply to operators on commercial vessels. Please enquire with your local licensing authority for full details.

To enter the vessel's MMSI number -

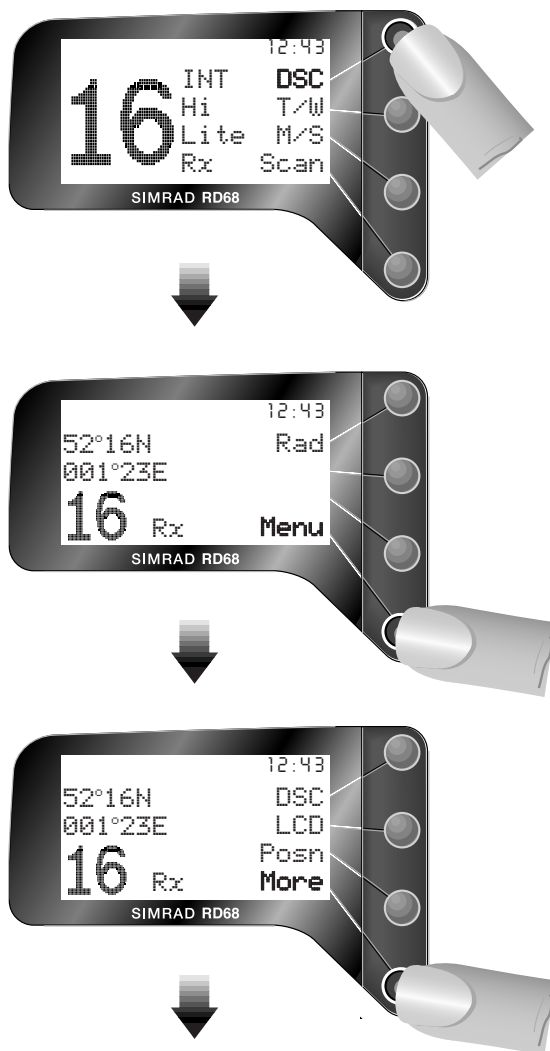

continued on next page -

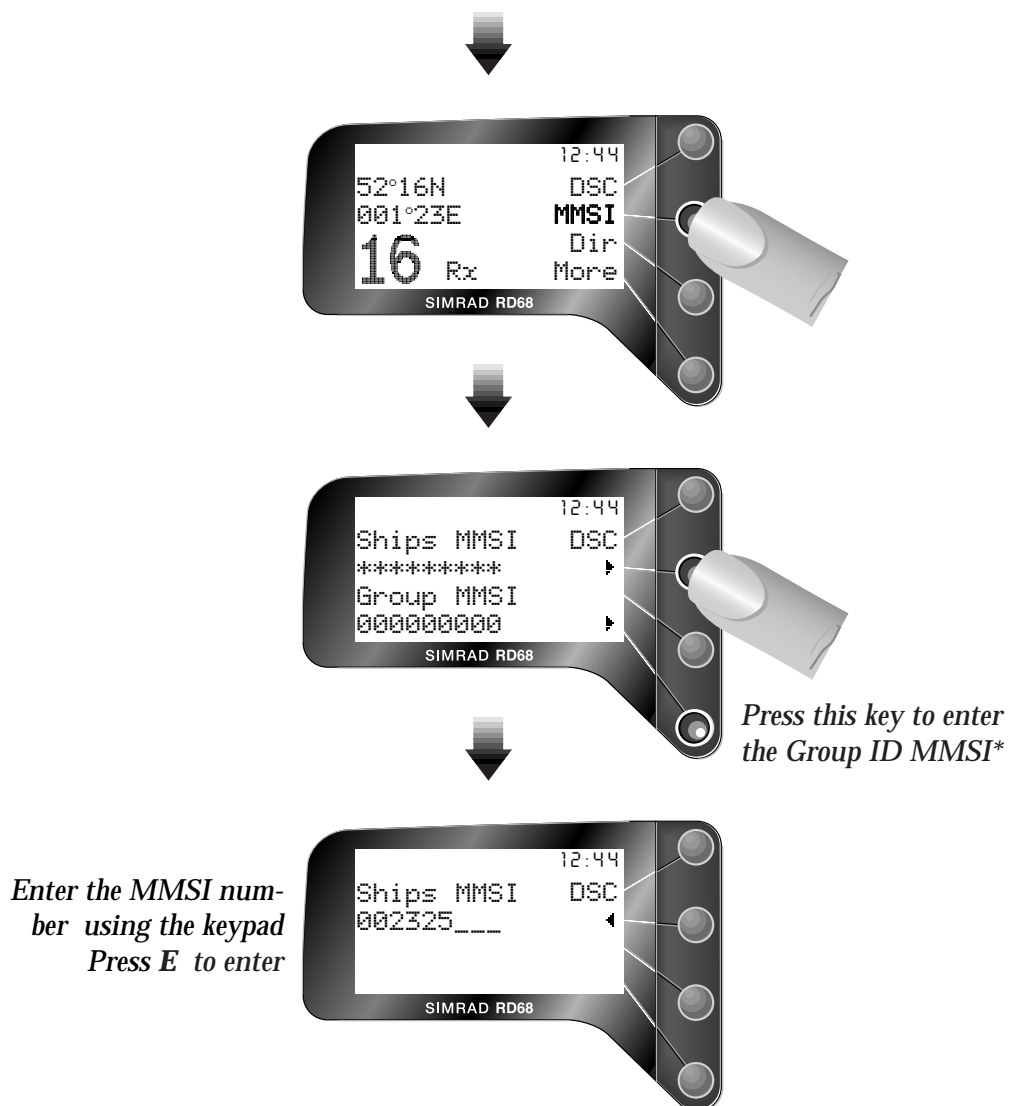

**NOTE** If an error is made, press **◀** to move back and edit the number.

You will be asked to confirm the number. Re-enter the MMSI and press **E**.

**WARNING** It is important that the MMSI entered is checked carefully, as it can only be entered once. To change the MMSI number after it has been programmed the unit must be returned to an authorised Simrad Dealer to erase the existing number.

*\* The Group ID MMSI number can also be entered here - unlike the vessel MMSI number, this can be changed later .*

## 2 OPERATION

### 2.1 General

The RD68 VHF is very simple to operate, with the controls falling into five groups -

1. The rotary Volume/On/Off & Squelch controls.
2. The **alphanumeric keypad** used to select the channel, MMSI number etc.
3. The **dedicated controls**, for commonly used functions such as output power, dual watch and channel 16 select etc.
4. The four **softkeys** to the right of the display change their function depending on what is displayed. The labels showing the current function of each key is shown on the respective line on the right side of the display.
5. There is also a **Distress alert button** under a sliding cover. **This must only be used in an emergency - see section 5.1.**

The radio functions are split into two main modes -

- **Radio Mode** allows access to the standard VHF radio functions, such as tri watch, scan etc.
- **DSC Mode** covers the Digital Selective Calling functions.

These modes are toggled by pressing the top softkey (labelled **DSC** or **Rad**).

At any stage of the DSC Mode menu structure, pressing the **DSC** softkey will return to the DSC Mode main menu.

At any stage of the DSC Mode menu structure, pressing the **C** key will cancel any unconfirmed action or step back one level in the menu structure.

Some menu options will only be displayed if the relevant information is available.

If the radio is receiving NMEA GPS data the current Lat/Long will be displayed when in DSC Mode, and the time will be displayed in both Radio and DSC Modes in 24 hour UTC (GMT) format (the local time can also be entered).

### 2.2 Rotary controls

The radio is switched on by turning the volume knob clockwise. To increase the volume, turn the knob further clockwise. Turn the knob fully anticlockwise to switch off.

The squelch knob is used to adjust the receiver muting threshold (squelch) level. To cut out weaker signals, increase the squelch until the background interference noise disappears. To receive weaker signals, decrease the squelch.



## 2.3 Backlighting (☼)



There are five levels of brightness - press and hold the ☼ key to step through and release when the required level is shown.

## 2.4 Changing channel

### 2.4.1 Standard International channel



*If channel selection is not confirmed within 2 seconds (by pressing E), the radio will revert to the original channel*

**NOTE**

To select channels, the RD68 will need to be in Radio Mode. If in DSC mode, press the **Rad** softkey before entering the channel number.

## 2.4.2 Auxiliary & Private channels

NOTE

Only available if channels are programmed into radio.

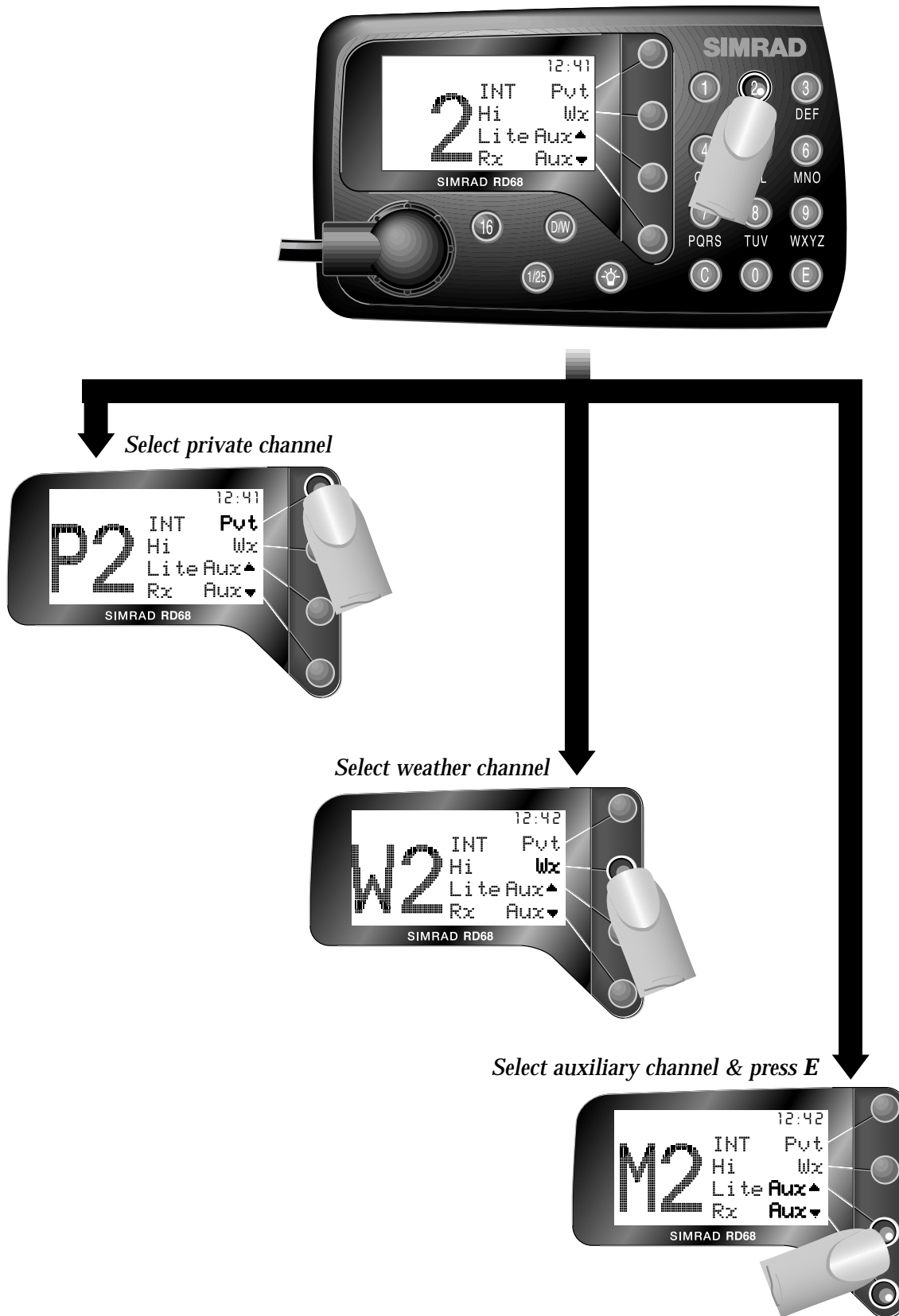

## 2.5 Transmit power

Toggles transmit power between 25w (**Hi**) and 1w (**Lo**) for short range transmissions, for example when in a marina. This preserves battery power.

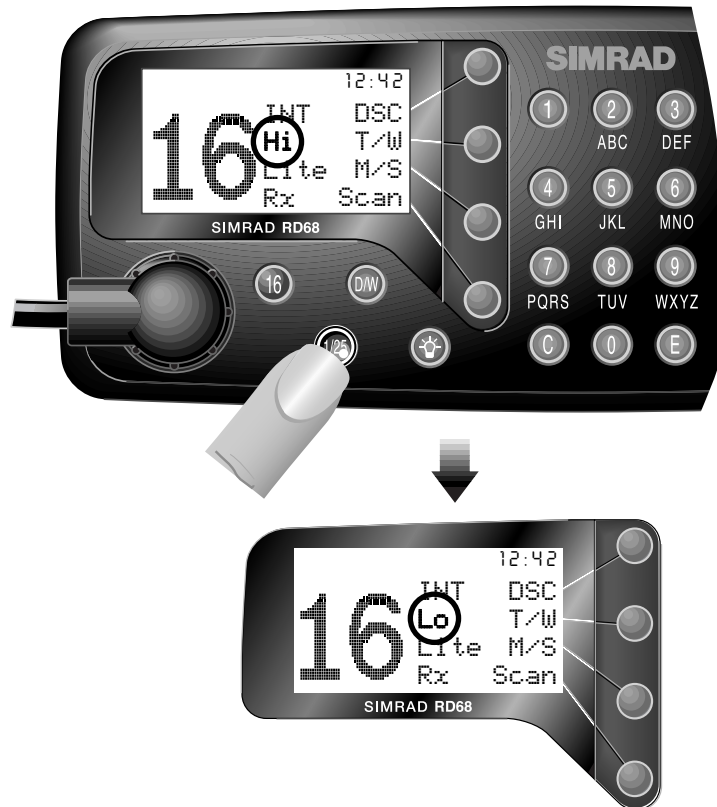

### NOTE

Regulations restrict some channels, such as 15 and 17 to low power only, in which case this key will have no effect.

## 2.6 Making a DSC call

Press the **DSC** softkey to enter DSC Mode.



continued on next page -

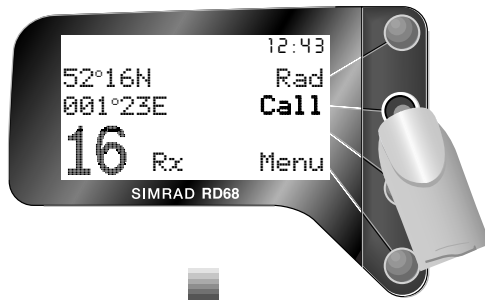

*Press **Type** to scroll through the different types of call*

*Manual MMSI entry*

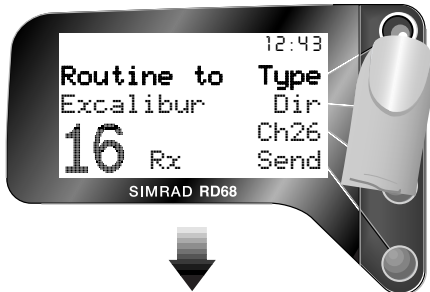

*Use **←** key to correct any mistakes*

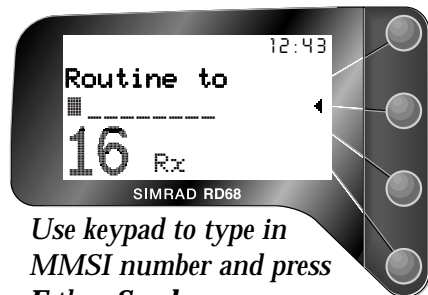

*Use keypad to type in MMSI number and press **E** then **Send***

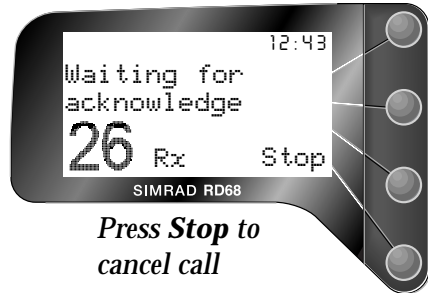
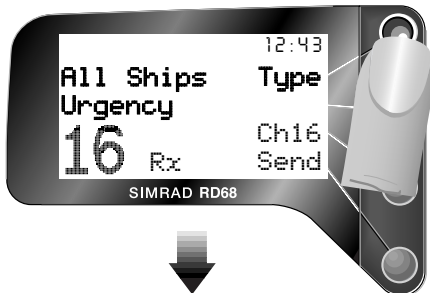
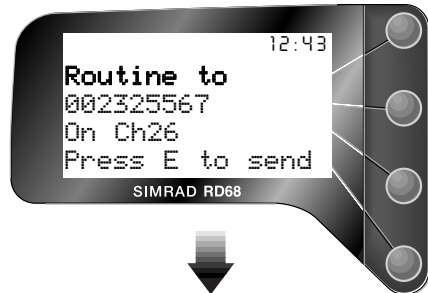
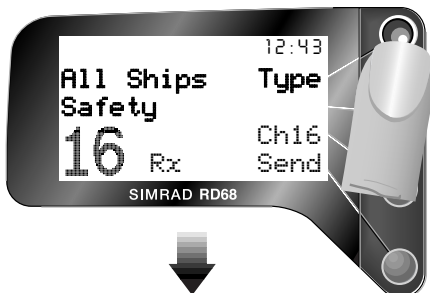

*Press **Stop** to cancel call*

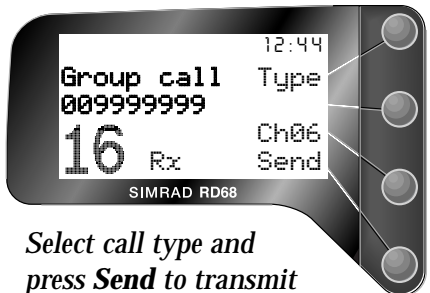

*Only displayed if a group MMSI number has been entered (see section 1.3)*

*Select call type and press **Send** to transmit*

*continued on next page -*

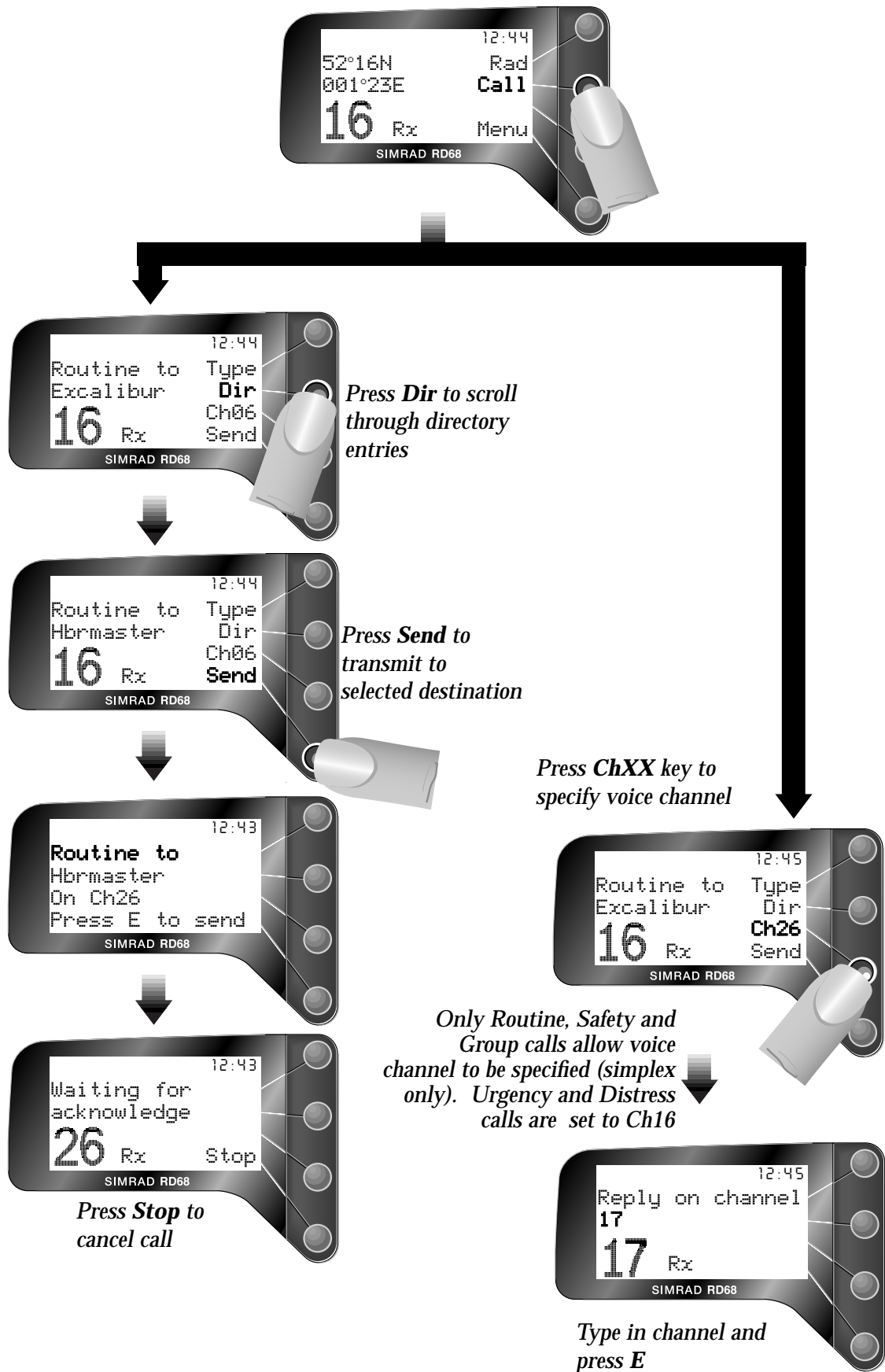

## 2.7 Making a distress alert call

### WARNING

This call should only be made if the vessel is in a genuine distress situation. It is an offense to send a Distress Alert call if the vessel or crew are not in danger. Refer to section 5.1 for more details.

The distress button is located under a protective cover that must be slid back before the button can be pressed. Press the **Distress** button to access the distress alert screen -

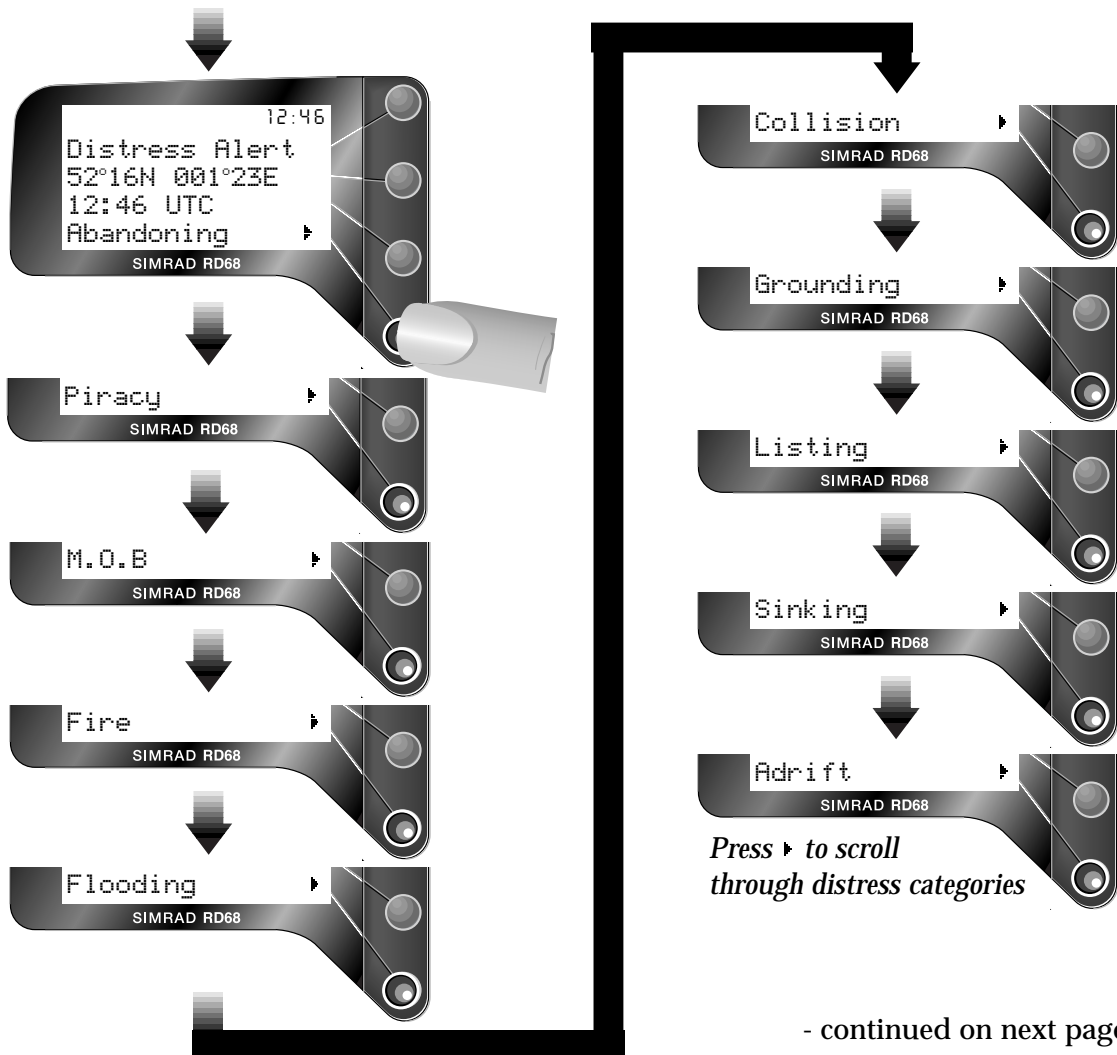

- continued on next page



Press and **hold** the **Distress** key a second time for five seconds. A countdown to the transmission will be displayed. Release the key at any time during this countdown to abort the transmission and press **C** to return to the main menu.

The Distress Alert transmission contains the following data -

- The vessel's MMSI
- The vessel's position (either from the NMEA0183 input, or manually entered)
- The time (from NMEA or manual)
- The nature of the distress

**NOTE**

If the boat's position and time are not being received via the NMEA interface then the display will allow this data to be entered manually - refer to section 3.2 for more details.

After the Distress Alert has been sent, the RD68 will tune to channel 16 and will automatically repeat the Alert approximately every four minutes until either an acknowledgement is received, or **C** is pressed (it is not recommended that the Distress Alert is cancelled manually by pressing **C** unless you are requested to do so by the rescue authorities).

While the Distress Alert remains active, an intermittent alarm will continue to sound.

When an acknowledgement is received from the Rescue Co-ordination Centre, this will automatically cancel the Distress Alert transmission. The subsequent rescue co-ordination will be performed using the voice working channel.

## 2.8 Receiving a DSC call

When a call is received, the RD68 will ring and the display will show the call information.

Press **Ack** (for Individual calls requesting acknowledgement only) or **OK** to cancel ring and switch to the working channel.

Press **Stop** to cancel ring only.

*Individual Routine call*

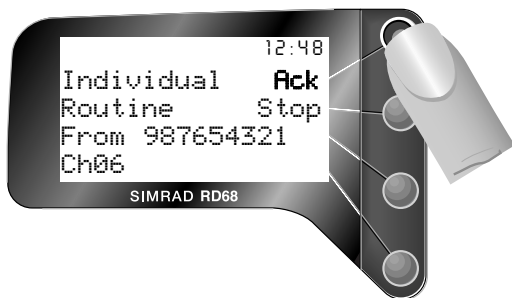

*Individual Routine call from  
MMSI stored in directory*

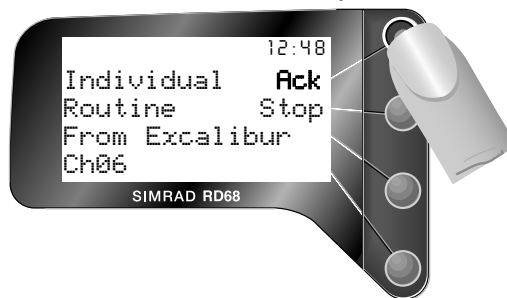

*All Ships Safety Call*

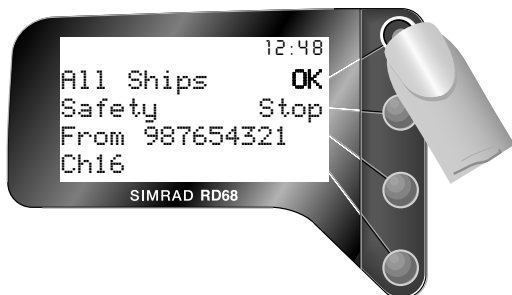

*All Ships Urgency Call*



*Group Call*

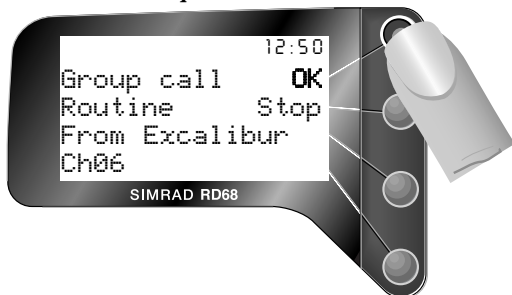

*Distress Alert Call*

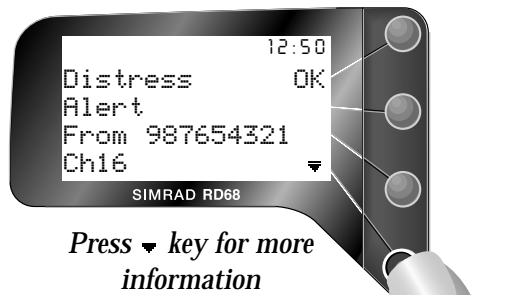

Press **▼** key for more  
information

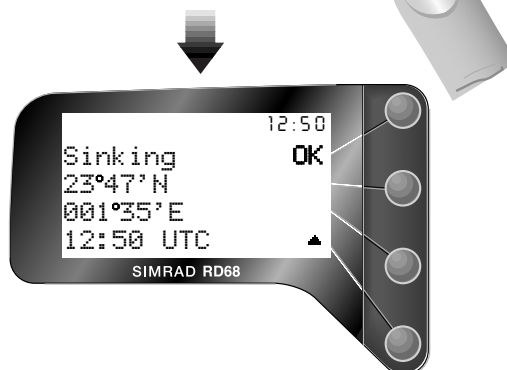



## 2.9 Dual watch

Dual watch allows the radio to scan between the selected working channel and the priority channel (normally 16).

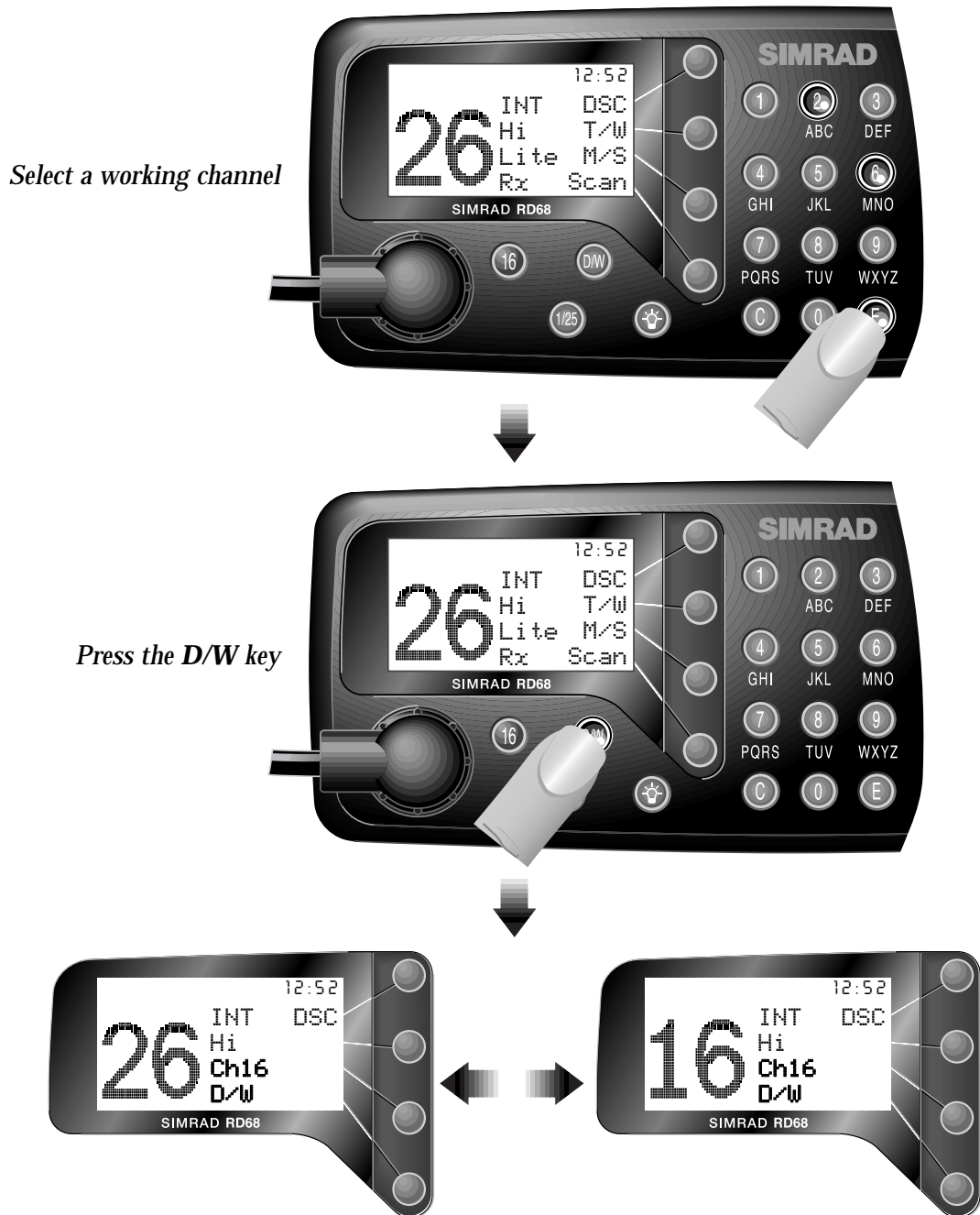

*The RD68 will monitor the working channel and the priority channel sequentially*

### NOTE

Normal VHF functions will not be available when in dual watch mode. To change channel or transmit press **16**, **D/W** or **C** to exit dual watch. DSC functions can still be accessed by pressing **DSC**, but sending a DSC call will automatically cancel dual watch.

## 2.10 Tri watch

Tri watch operates on the same principle as dual watch, however this function scans between the working channel, priority channel and the user channel. For more information on the user channel and how it is specified, please refer to section 2.13.

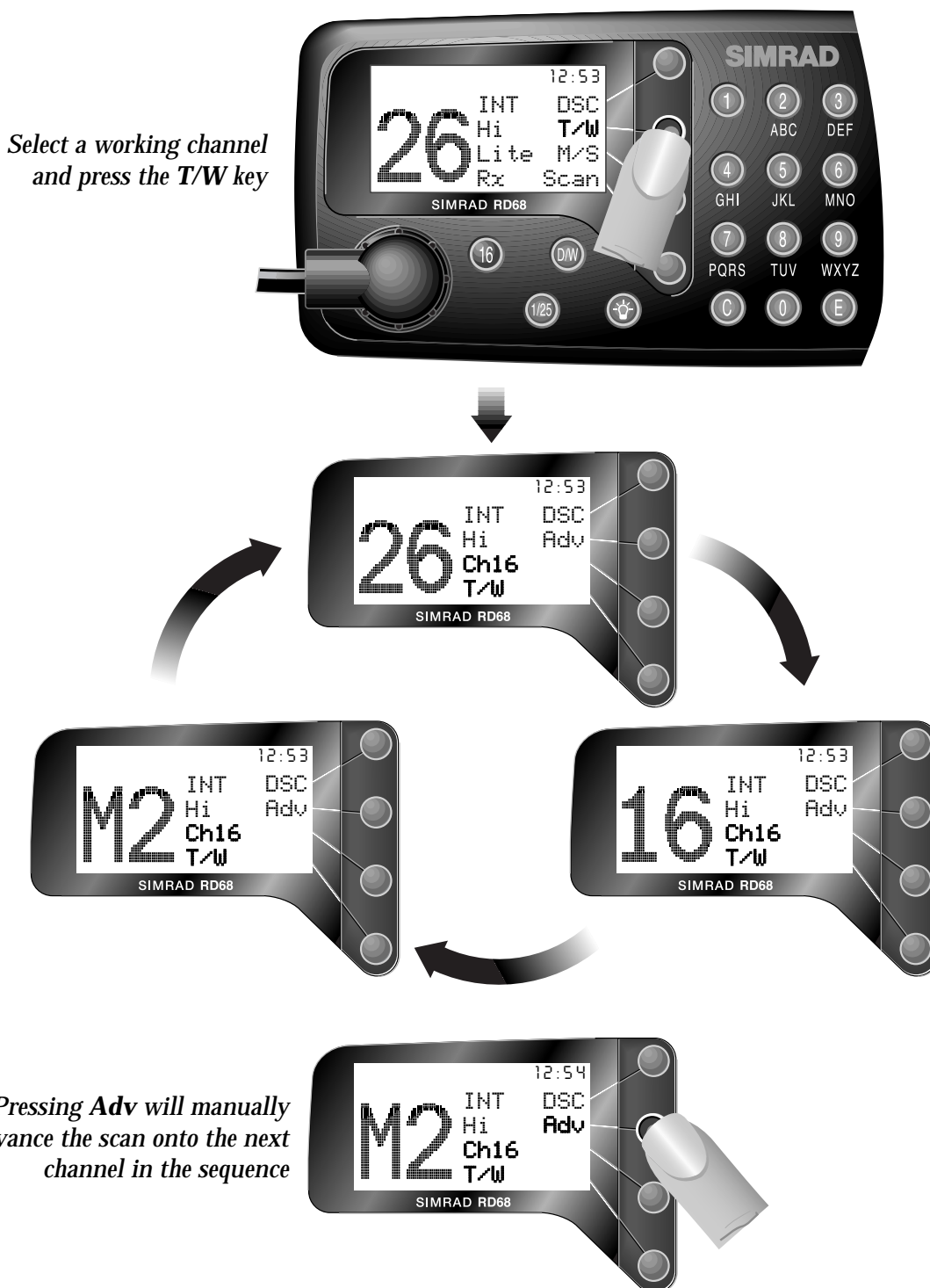

### NOTE

As with dual watch, normal VHF functions will not be available when in tri watch mode. Exit tri watch by pressing **16** or **C**.

## 2.11 Scan mode

The scan function cycles the RD68 sequentially through each enabled channel, pausing when a signal is detected.

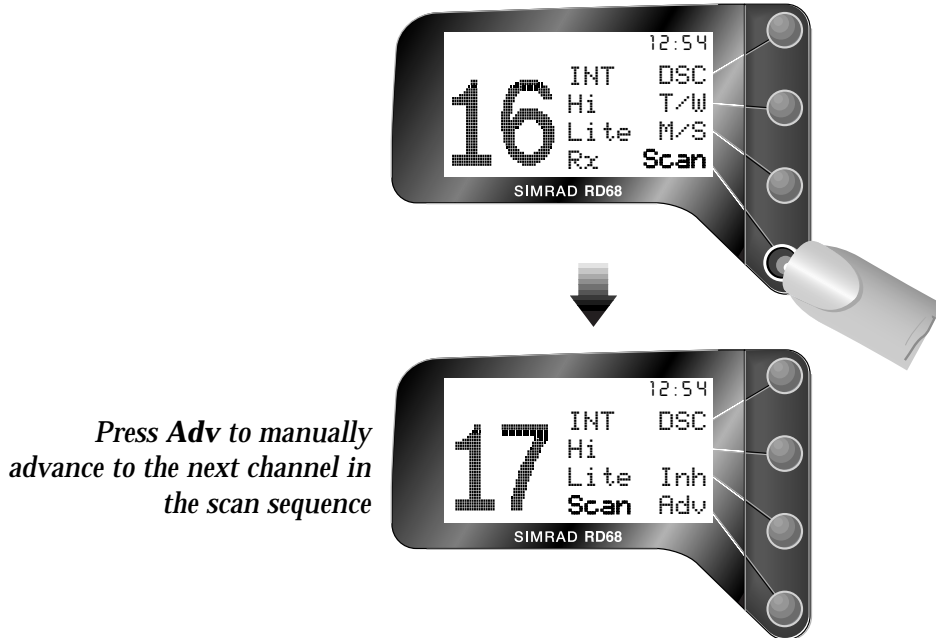

**NOTE**

While in scan mode, normal VHF functions are not available. To exit scan mode, press C or 16.

### 2.11.1 Inhibit / enable channel from scan

In some areas the scan function may repeatedly lock on a channel at each cycle, for example if it is transmitting a carrier signal. Rather than press Adv each cycle, selected channels may be inhibited, or removed from the scan cycle -

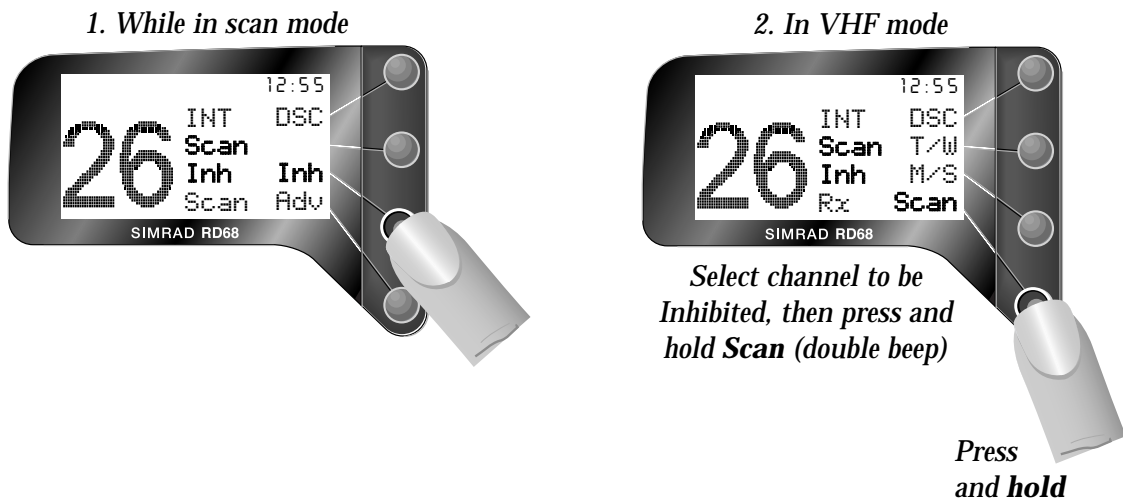

To re-enable an inhibited channel into the scan cycle, repeat sequence 2 -

*Select channel to be enabled  
then press and hold Scan  
(double beep)*

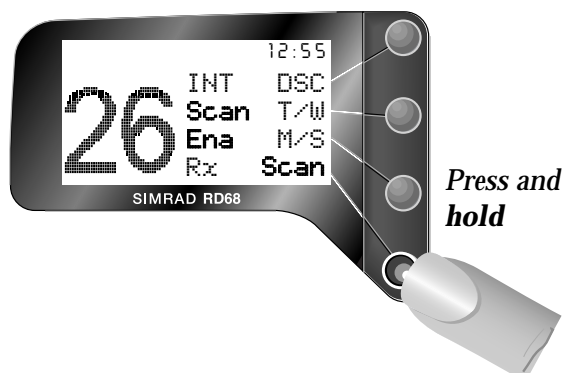

## 2.12 Memory scan

Like the scan function, memory scan will cycle sequentially through the channels, but only those which have been pre-selected (refer to the next subsection 2.12.1 for more information on preselecting memory scan channels).

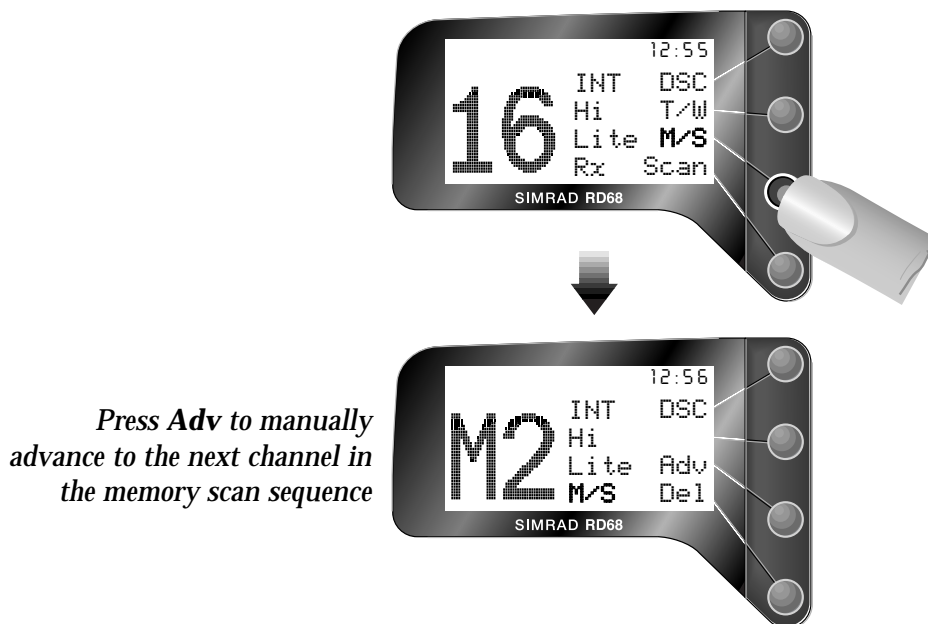

### NOTE

While in memory scan mode, normal VHF functions are not available. To exit memory scan mode, press C or 16.

### 2.12.1 Add / remove memory scan channels

To add a channel to the memory scan cycle -

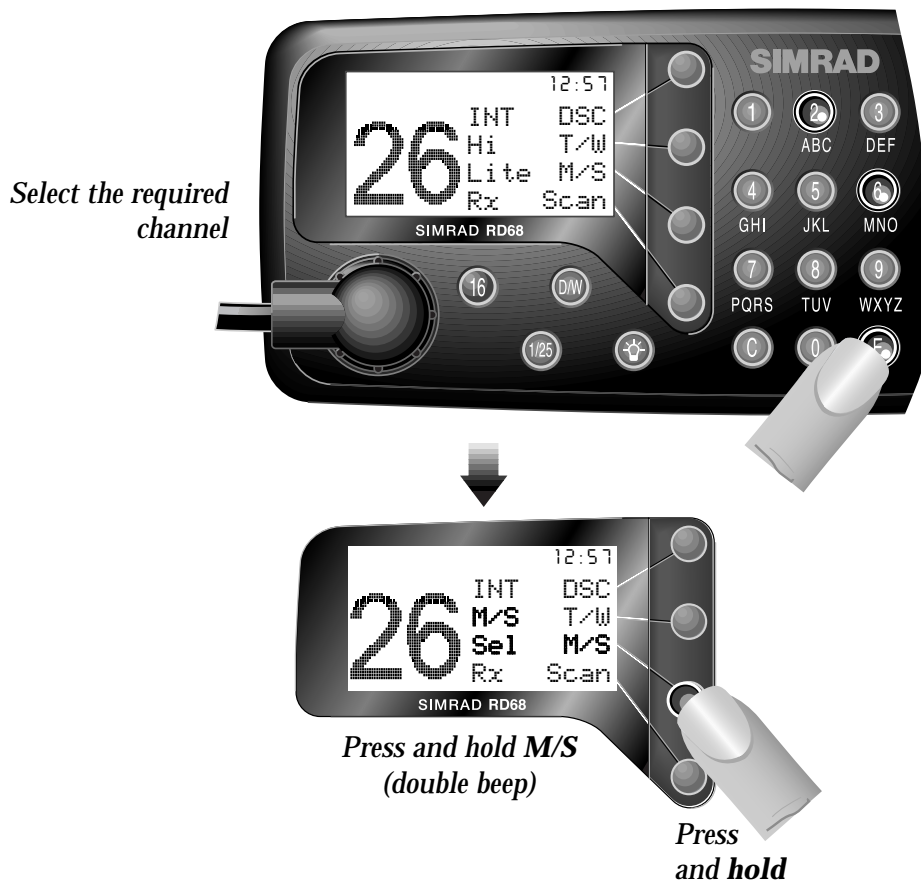

To delete a pre-selected channel from the memory scan cycle -

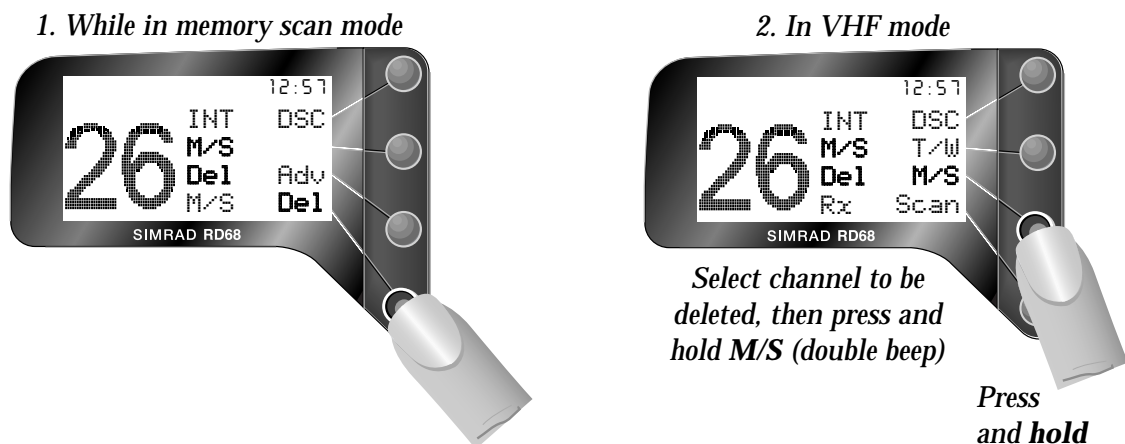

## 2.13 Priority & user channel select

The priority channel (usually 16, depending on the configuration of the RD68) can be accessed immediately by pressing **16**. This will cancel any function currently in operation.

The user channel is a programmable priority channel, which is accessed by pressing **16** twice -



*Press 16 twice*

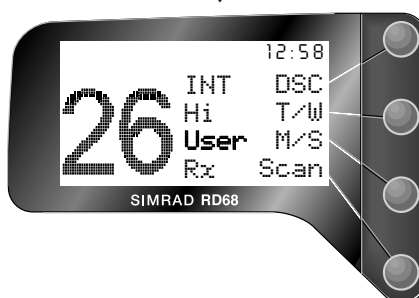

### 2.13.1 Programming user channel

*Select the required channel  
Press and hold T/W  
(double beep)*

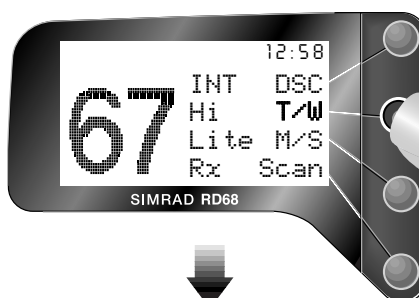

*Press  
and hold*

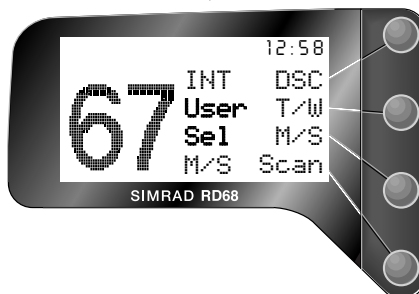

## 2.14 Viewing the call log

The last 16 incoming DSC calls are logged by the RD68 and can be viewed later (this function will not be displayed if no calls have been received) -

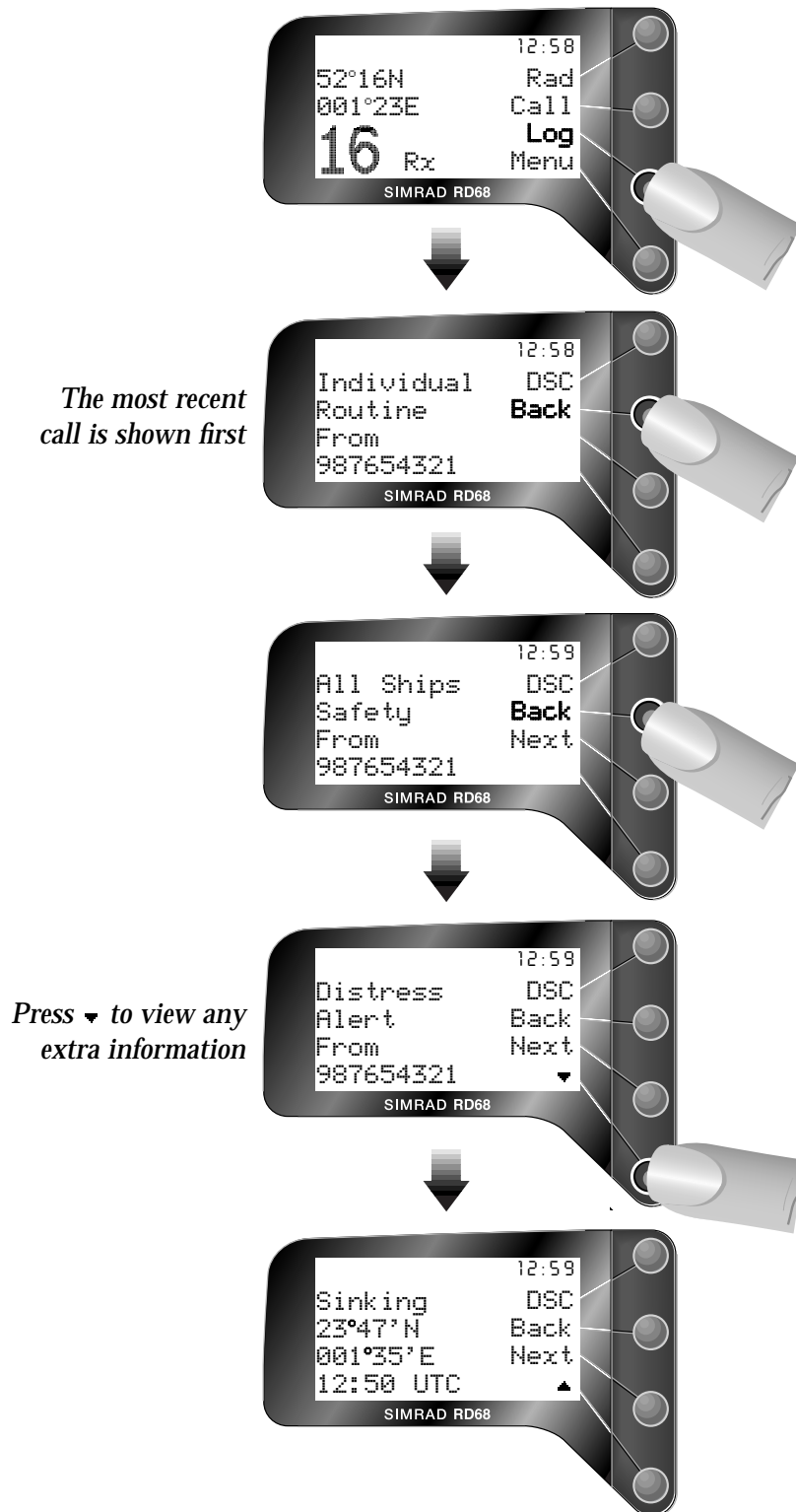

## 3 MISCELLANEOUS FUNCTIONS

### 3.1 Adjusting LCD contrast

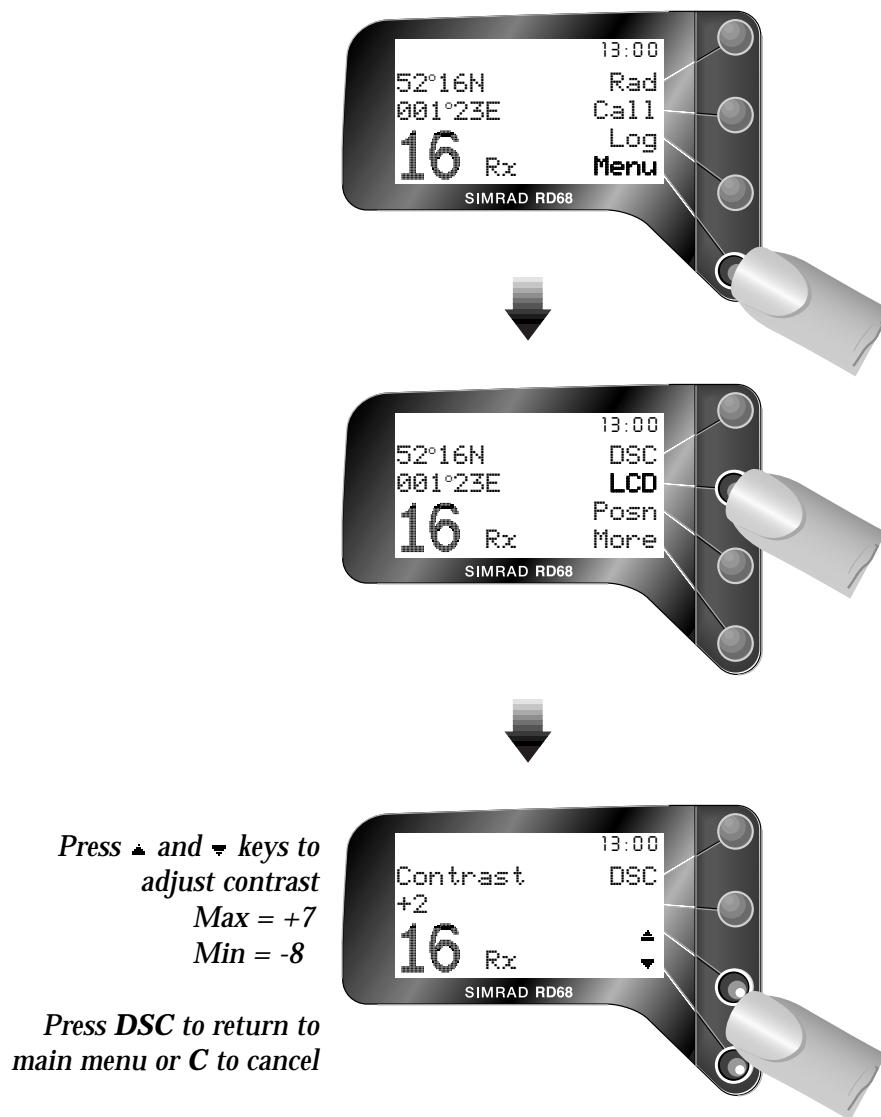



### 3.2 Entering manual position & time

The boat's position and the time (which is transmitted as part of a Distress Alert call) would normally be from an interfaced GPS. If this is not available, the information can be manually entered -

*If no GPS information is being received, the clock is not shown and the display shows "No position available"*

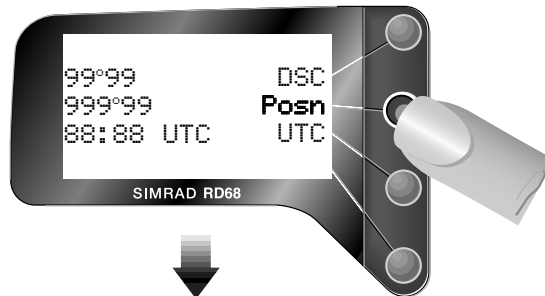
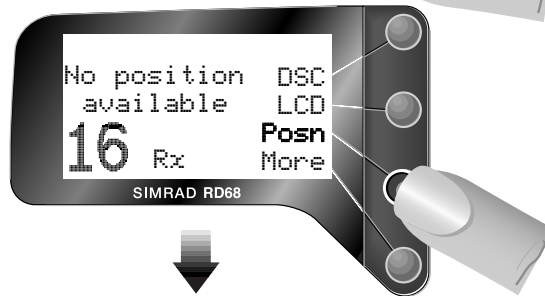
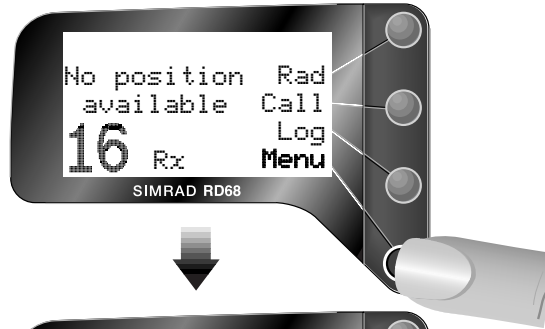

*Enter Lat and Long using the keypad*

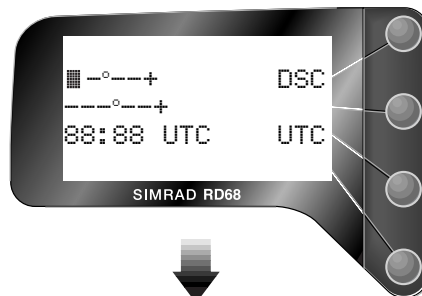

*Press N or S for Latitude*

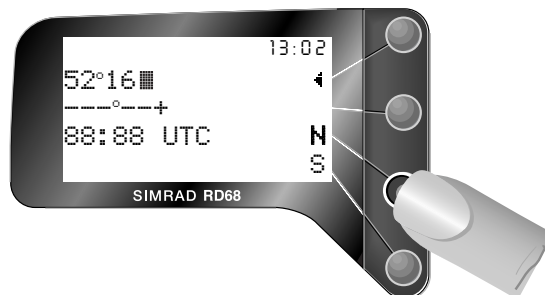

continued on next page -

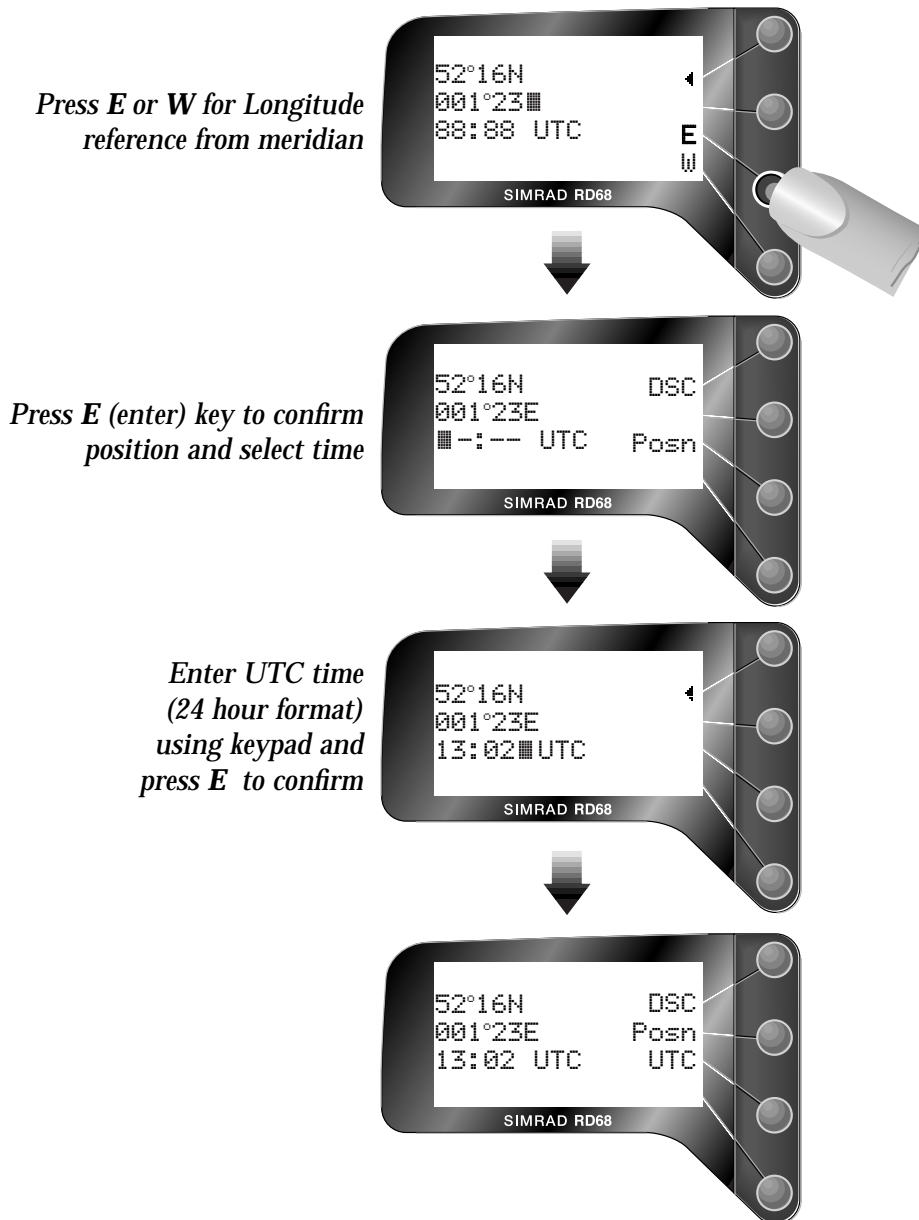

**NOTE**

The display will now show the manual Lat and Long when in DSC mode, but the clock display will not be shown (this is only available if NMEA position and time data is being received).

This option will not be available if position and time data is being received via the NMEA input.

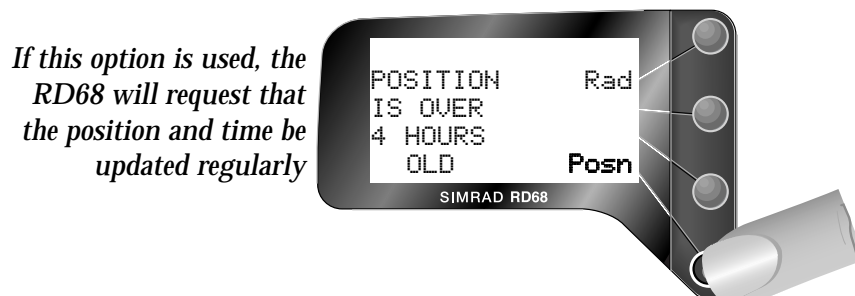

### 3.3 Entering local time

When a GPS is connected to the RD68 via the NMEA interface, the display will show the UTC (GMT) time in the top right corner. This can be changed to the local time if required -

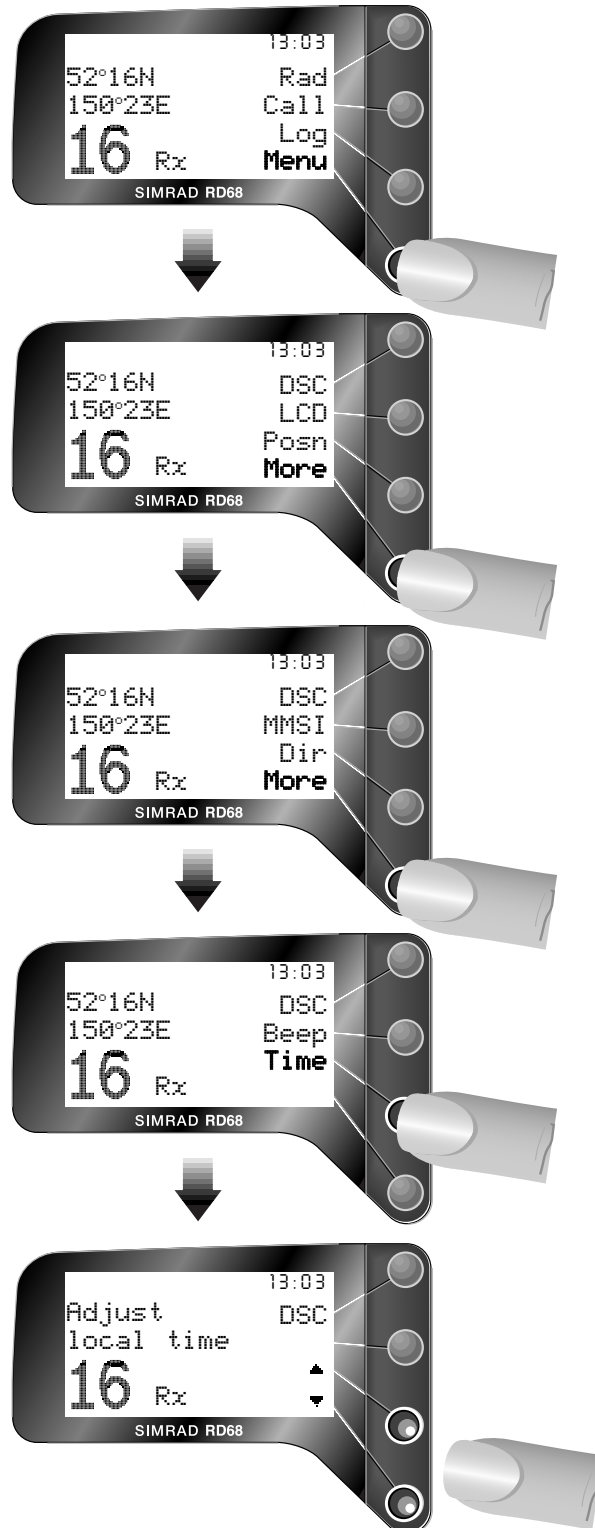

*Use arrowed keys to adjust to local time and press DSC to return to main menu*

continued on next page -

*Display will now show local time*

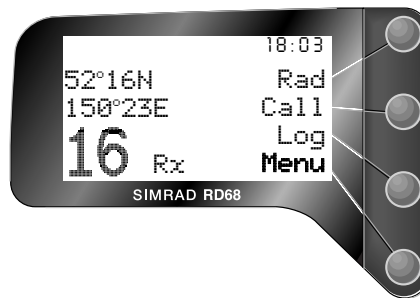

### 3.4 Viewing the directory

The directory allows up to 16 MMSI numbers to be stored in the RD68's memory. These can then be recalled when making an individual routine call -

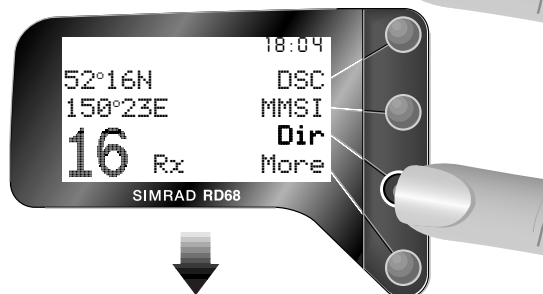
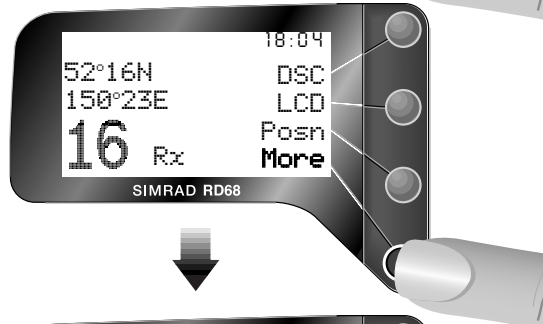
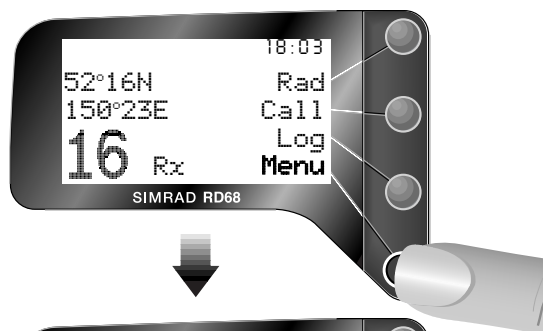

*The main directory screen shows the number of directory entries*

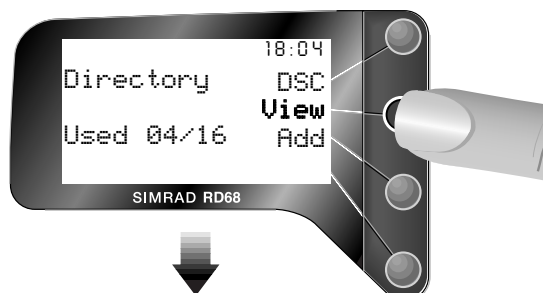

continued on next page -

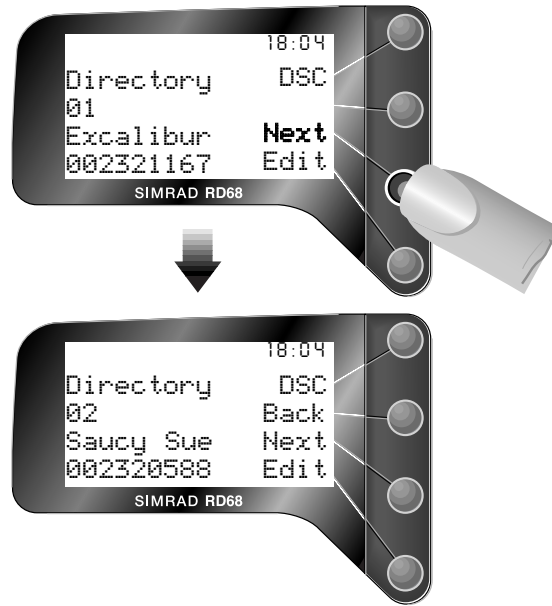

### 3.4.1 Adding entry to directory

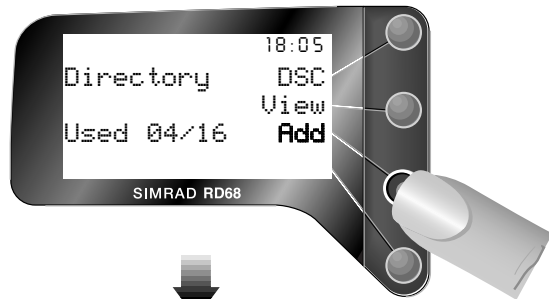

*Enter name using keypad(10 chars max)-*

1 Press	0	sp	A	D	G	J	M	P	T	W
2 Presses		1	B	E	H	K	N	Q	U	X
3 Presses			C	F	I	L	O	R	V	Y
4 Presses			2	3	4	5	6	S	8	Z
5 Presses							7		9	

*Press E to confirm name entered -*

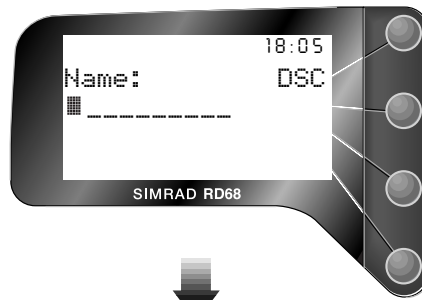

*Enter MMSI number  
Press E to save entry to directory*

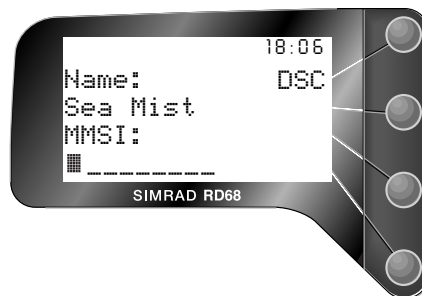

### 3.4.2 Editing / deleting entry

To edit an existing entry -

*The main directory screen shows the number of entries*

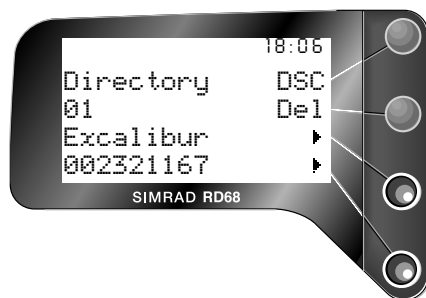
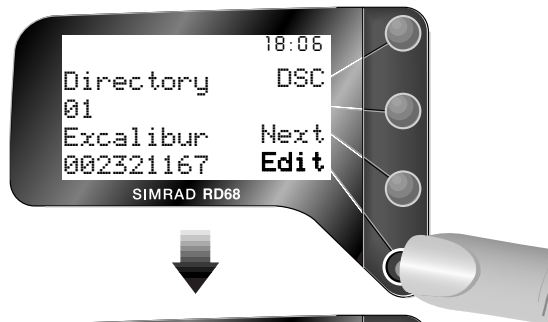
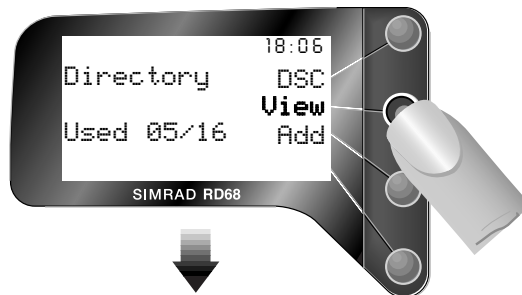

*Edit MMSI Number*

*Re-enter the MMSI using the keypad. Press E to enter*

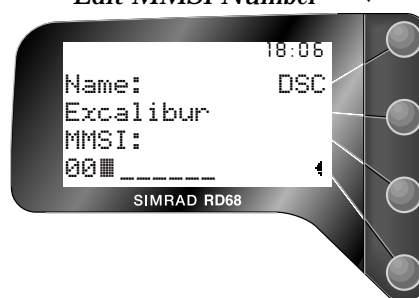

*Edit Name*

*Re-enter the name using the keypad. Press E to enter*

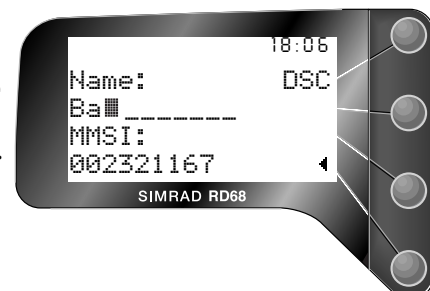

To delete an entry from the directory -

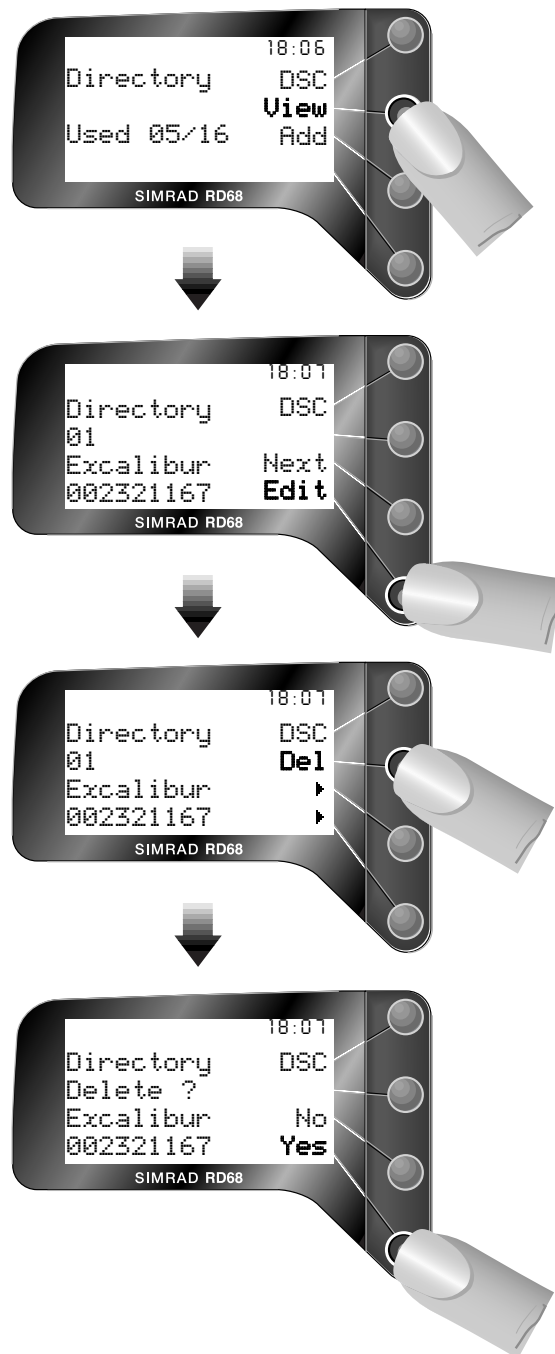

### 3.5 Disabling key beep

All key presses on the RD68 are normally confirmed by a “beep”, but this can be disabled -

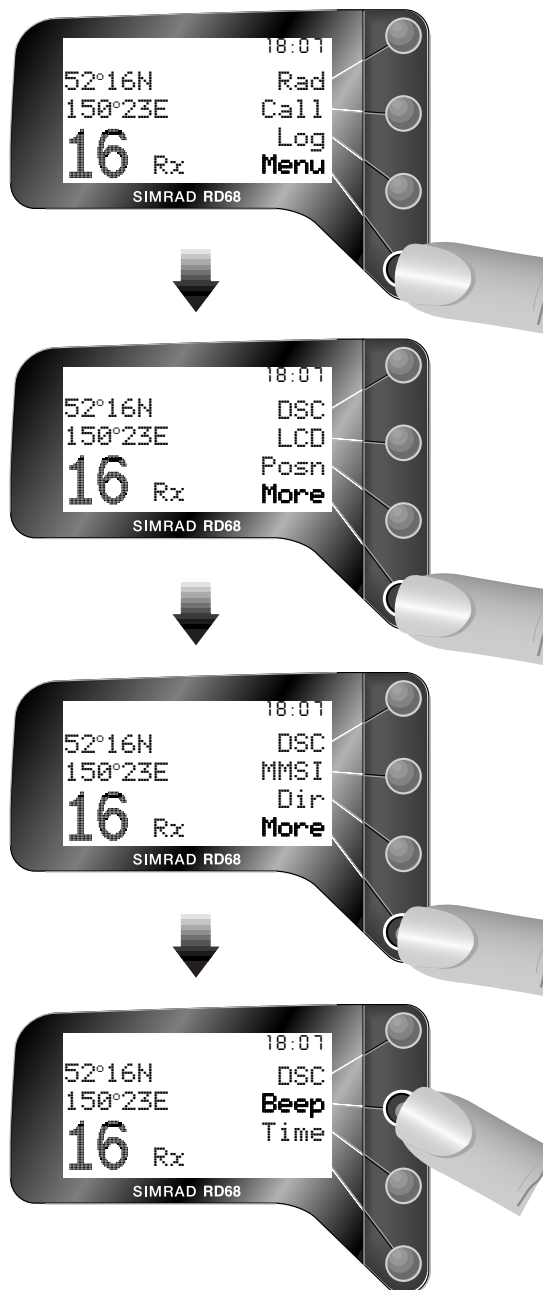

To re-enable the key beep, repeat the above key sequence.

#### NOTE

This will disable the key beep on all first level functions. Second level functions which are accessed by pressing and holding a key (eg setting the user channel or adding a channel to the memory scan cycle) will still be audibly confirmed by a double beep - this cannot be disabled.



### 3.6 Second channel mode

In countries where it is permitted, the RD68 can operate on a secondary set of channels, such as the USA channels -



**NOTE** Channel sets available will depend on programming. Please enquire with your national licensing authority for details of permitted channel sets in your own country.

**NOTE** The radio will revert to International channels if it is switched off.

### 3.7 Speaker mute (handset models only)

On radios fitted with a handset, lifting the handset from the cradle will normally mute the loudspeaker. However, this can be disabled so that the loudspeaker will remain on when the handset is lifted and incoming transmissions will be heard both in the handset earpiece and the loudspeaker -

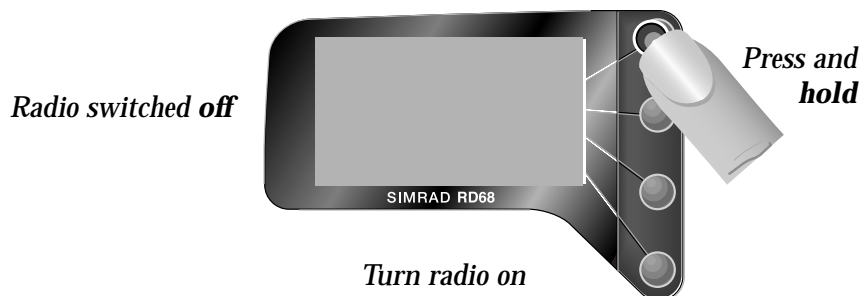

To restore speaker muting, repeat the above procedure.

## 4 INSTALLATION

### 4.1 VHF installation

The radio should be sited so that engine noise and vibration or other background noise do not make it difficult for the operator to hear.

Although the RD68 radio is waterproof when flush mounted, it is recommended that it is not installed where it will be exposed to continuous direct sunlight, as this will eventually damage the LCD display.

As microphones and loudspeakers contain powerful magnets, the radio should not be installed within 1m (3ft 3in) of any compasses, whether magnetic or electronic.

The fins on the back of the case act as a heatsink to dissipate heat generated by the set when in use, which maintains the high efficiency of the radio. The free circulation of air is essential - if mounting the radio in an enclosed space, ensure that the space is vented.

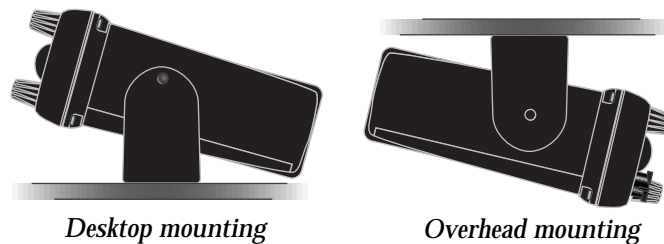

*Fig 4.1 - Standard mounting options*

The VHF is supplied with a reversible mounting bracket. This can be used to mount the VHF on the chart table or on an overhead bulkhead (Fig 4.1). The bracket is fixed in place using four No.10x3/4 screws (supplied). Before installing, ensure that there is at least 88mm (3.5 in) vertical clearance and 70mm (2.8in) horizontal clearance behind the bracket to allow the radio to fit (Fig 4.2).

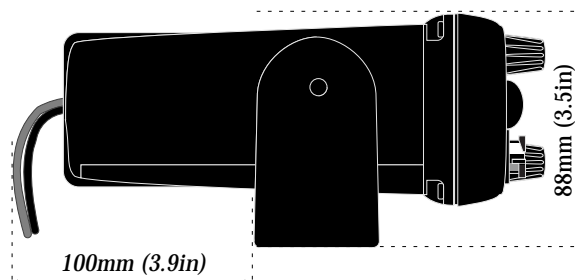

*Fig 4.2 - Minimum clearance required*

The radio is fixed to the bracket using a simple clamp arrangement. The peg on the left side of the radio is slotted into the hole in the bracket. The clamp on the right side of the radio can then be slid into the slotted aperture on the bracket and tightened to hold the radio firmly in place (Fig 4.3). The rake angle of the radio can be adjusted by slackening the clamp.

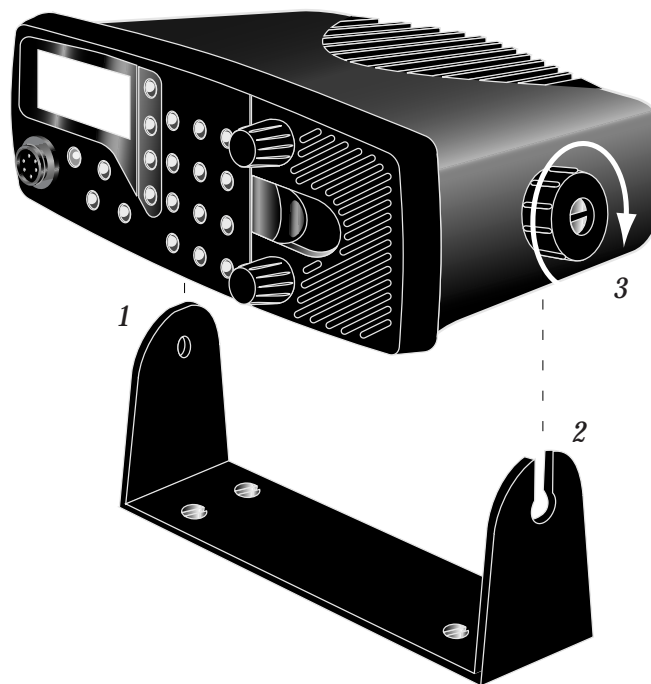

1. Fit locating peg (left side) into hole in bracket
2. Slide locking clamp (right) into slot in bracket
3. Tighten clamp

*Fig 43 - Fixing VHF to bracket*

An alternative mounting method is to use the flush mounting kit FMB1000BK (supplied separately). This allows the radio to be neatly installed inside a bulkhead, so that only the fascia of the radio is visible. For more details of this and other accessories available, please refer to section 5.2.

The RD68 has five electrical connections - the handset/fistmike socket is on the front panel below the LCD display (Fig 4.4A). The other four are situated on the back of the case - the antenna socket is on the left (Fig 4.4B). DC power is supplied to the set via a two core flying lead (Fig 4.4C). The NMEA input connections (4.4D) allow a GPS to be interfaced, below which is a 3.5mm jack socket for an optional extension speaker (Fig 4.4E) - this is covered by a weather plug when not in use.

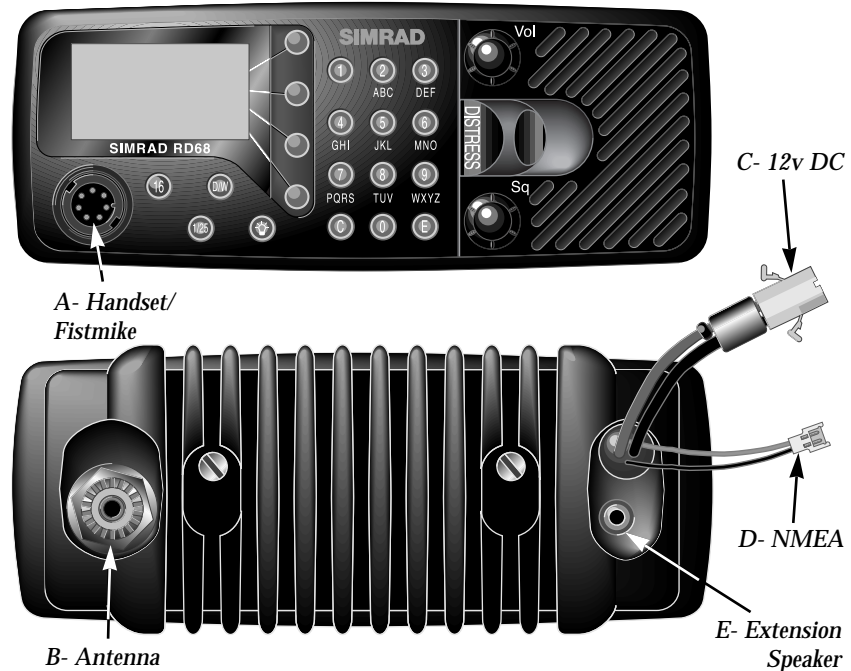

Fig 4.4 - External connections

The VHF requires a 12v DC supply to operate, and is supplied with a power lead which incorporates an in-line 7.5 amp fuse. This lead should be connected to the vessel's power supply, keeping the cable runs as short as possible. Although the radio draws very little current when receiving, a heavier current is drawn when transmitting which may result in a voltage drop if long cable runs of inadequate core diameter are used. If the supplied power lead is not long enough, an extension of up to 3m (10 ft) can be made using at least 2.5mm<sup>2</sup> (13AWG) wire.

**The red wire is positive and black is negative.** If polarity is accidentally reversed, the set is protected but the fuse will blow. Ensure that it is replaced with a fuse of the correct 7.5 amp rating. The radio is designed to be easily removable for storage or security, so leave an adequate length of cable to ease disconnection. The flying lead from the rear of the radio can then be plugged into the power supply lead. Note that the configuration of the plug prevents incorrect connection.

The antenna is connected to the radio using a standard PL259 type connector as fitted to most marine antennae. If fitting to an existing antenna, check that the contacts are not corroded before connecting, as this will affect the quality of the signal. Ensure that the retaining collar of the antenna plug is securely tightened to prevent accidental disconnection.

For NMEA interfacing to an external navigation source (eg a GPS, Loran or chart plotter), the RD68 is supplied with a 1m cable assembly which plugs into the lead at the back of the radio. The other end is connected to the navigator as follows -

Wire colour	To navigator connections -
Red	NMEA OUT Data (+)
Blue	NMEA OUT Common (-)



Fig 4.5 - Linking to navigation source

**NOTE**

If the navigator does not have a dedicated NMEA common terminal, the blue wire should be connected to the 0v terminal of the navigator.

The extension speaker socket takes a standard 3.5mm jack plug. The speaker used must have a minimum impedance of 8Ω.

## 4.2 Antenna installation recommendations

The most important factor in the performance of the radio will be the quality and positioning of the antenna. Most recorded problems with VHF radios are related to poor antenna siting, faulty cabling, poor quality cable joints and low voltage supply. Even a VHF as highly advanced as the RD68 cannot compensate for these factors. Therefore, if replacing an existing VHF installation, it is important that the antenna is thoroughly checked for any faults or damage before use.

As the range of VHF signals are governed by line of sight (see section 4.2), the antenna should be placed as high as possible, while remaining clear of any metallic objects that could influence the resonance of the antenna.

The most popular antennae for marine use are 1m (3ft 3in) long. On sail boats these are usually mounted on the mast-head, where the length of the antenna keeps it clear from the navigation lights and windvanes etc. This type of antenna can also be mounted on the cockpit roof or garage of power boats.

Longer whip antennae are recommended for larger boats - these radiate the same total power as smaller antennae, but concentrate it into a narrower beam, which is advantageous on a tall mast at extreme range where concentrating the available power into a narrow horizontal beam becomes more important. However, if the antenna is not vertical when transmitting, the beam will be angled either too high or too low (Fig 4.6) -

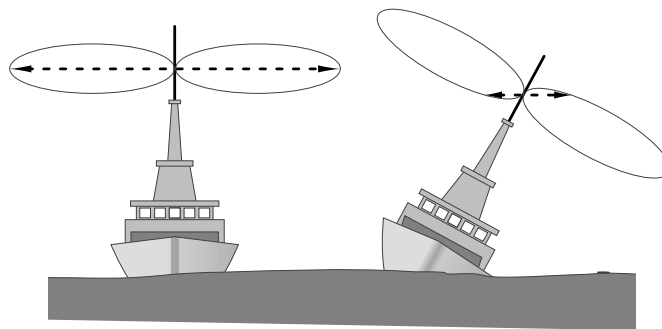

*Fig 4.6- Effect of heel on range of longer whip antenna*

Here the wider beam of the shorter antenna will be more universally effective, although the signal will be weaker (Fig 4.7) -

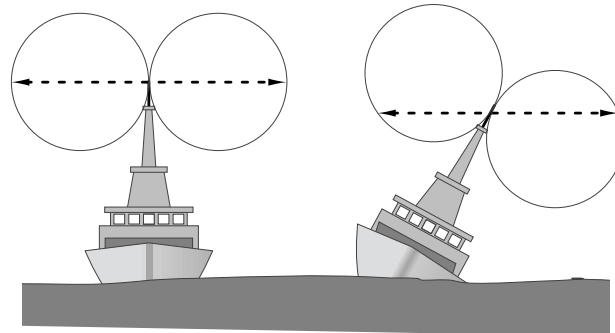

*Fig 4.7 - Effect of heel on range of 1m marine antenna*

Therefore vessels with a large heel angle (small sailboats) would be better choosing a short masthead antenna. Your local agent should be able to provide specific advice on antenna choice for the vessel it is to be fitted to.

#### **WARNING**

The antenna coaxial cable and any connectors used must be rated at 50Ω. *Under no circumstances should standard domestic TV cable and connectors be used.* Incorrectly rated cabling and connectors could result in power not reaching the antenna, but also power could be reflected back into the radio, damaging it in the process.

The quality of any connections and integrity of the cable (without breaks in the sheathing) will directly affect the performance of the radio. Poor soldering or corrosion of the terminals can impair performance. We recommend that screw or crimp terminal type connectors are not used for any through deck fittings - a good quality waterproof solder terminal connector will be less susceptible to poor connection due to corrosion of the contacts.

**NOTE**

If the RD68 detects a problem with the antenna or antenna connections, the display will show **ANT** when the PTT key is pressed. To avoid possible damage to the radio the antenna should be checked immediately for any damage or poor connection.

### **4.3 Electrical interference suppression**

Interference generated by the alternator of the engine may occasionally cause problems. The RD68 has been designed to minimise the effects of outside interference. However, precautions should still be taken - route the power supply and antenna cables away from the engine compartment. The cable run should not be down the same trunking as other cables carrying high current. The antenna cable should also be kept separate from the radio's power cable.

Engines with spark ignition - and also some refrigerators - should be fitted with suppressors. Your local agent should be able to give advice on this, and also supply suppression kits where necessary.

## 5 APPENDIX

### 5.1 Operating procedures

The following operating procedure summary has been proposed by the UK Maritime and Coastguard Agency. It is not exhaustive and should not be regarded as a replacement for information provided by the proper two day VHF/DSC training course required for all VHF license holders.

#### **Sending a distress alert**

1. Send a distress alert call (see section 2.7)
2. Wait approx 15 seconds for a DSC acknowledgement from the Coastguard or a ship station.
3. On receipt of a DSC acknowledgement or after about 15 seconds, transmit the Distress call on channel 16 -

*“Mayday, Mayday, Mayday”*

*“This is (name of vessel repeated three times)”*

*“Mayday”*

*MMSI number and name of vessel or callsign, spoken once*

*Position*

*Nature of distress*

If the vessel is not in “grave and imminent danger”, an All Ships Urgency call followed by a spoken “Pan Pan” call or a routine call to the nearest coastguard station may be more appropriate. It is a prosecutable offense to initiate a Distress Alert call for any other reason than that the vessel and/or crew is in imminent danger.

#### **Acknowledging and relaying a distress alert.**

When a DSC distress alert is received, an audible alarm will sound. Immediately cease any transmission that may interfere with distress traffic and continue a watch on channel 16.

If there is no DSC acknowledgement from a coast station or ship, after a short interval acknowledge by voice on channel 16 -

*“Mayday (MMSI of vessel in distress repeated three times)”*

*“This is (name of own vessel, repeated three times)”*

*“Received Mayday”*

*(State the assistance you can give).*

A similar response should be given to a distress relay, using the words “Mayday Relay” instead of “Mayday”.



## Canceling a distress alert

If a DSC distress alert is sent accidentally, cancel it immediately on the RD68 by pressing the C button to prevent repeats, then make the following announcement on channel 16 -

“This is *(name of vessel, callsign, MMSI)*”  
“Cancel DSC Alert sent *(date & time UTC)*”

Do not simply cancel the DSC alert without verbally cancelling it as well, otherwise the rescue authorities will not be aware that this is a false alarm.

## Alerting all vessels within range

If the vessel is outside of coast radio range and needs to issue a safety warning to all vessels within radio range, transmit an All Ships Safety call by DSC. After about 15 seconds transmit on channel 16 the safety call and message as follows -

“Securité, Securité, Securité”  
“All stations (or called station)” *repeated three times*  
“This is *(MMSI and name or callsign of own vessel)*”  
*Repeat text of safety message.*

## Calling a coast radio station

Enter the MMSI of the station into the RD68, either manually or from the directory. When the call is acknowledged, the working channel for voice communication will be indicated and the RD68 will automatically switch to that channel. Make a voice call as normal.

## Making an intership call

Enter the vessel's MMSI into the RD68, either manually or from the directory. Before sending the call, enter the inter-ship channel to be used for subsequent communication. When the alarm sounds on the called vessel, its operator should acknowledge by DSC, then respond by voice on the selected channel.

If the MMSI number of the vessel is not known, call as now on channel 16. If no response is received, call on channel 13. This is the GMDSS bridge to bridge communication channel.

## 5.2 Transmission range

Because VHF signals travel in a straight line and are not reflected back off the ionosphere as lower frequency signals are, the range of VHF signals is limited to 'line of sight', beyond which the other vessel passes behind the curve of the Earth. Therefore, the range will increase greatly the higher above sea level the antenna is, as Fig 5.1 illustrates (assuming maximum transmission power is used):

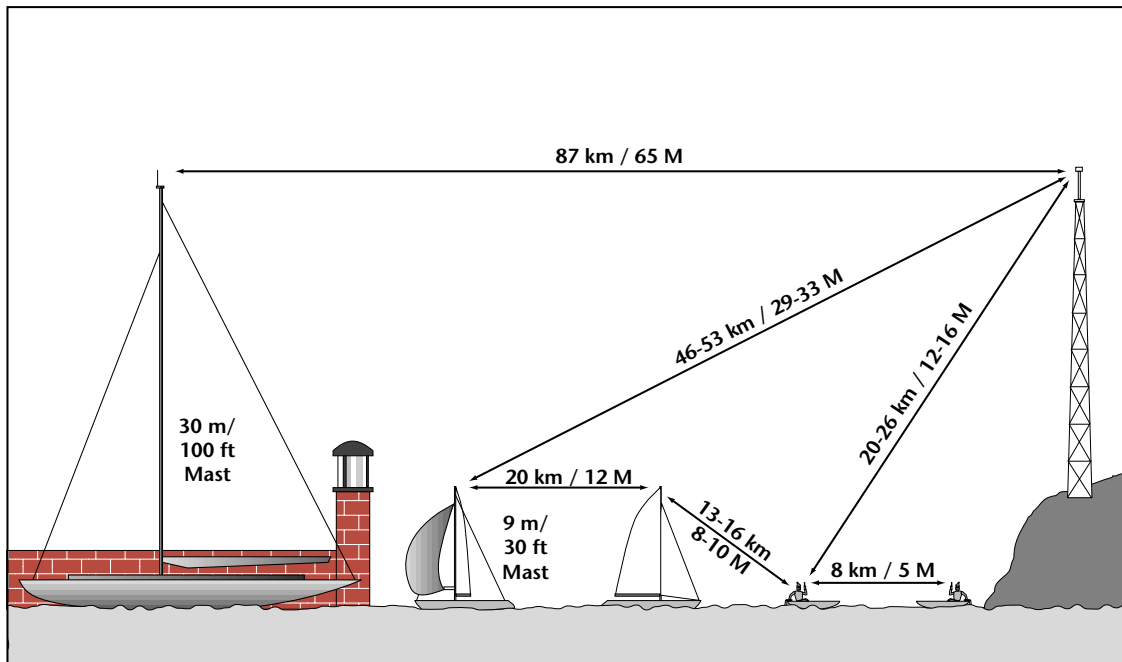

*Fig 5.1 - VHF transmission range*

Therefore, the typical ship to ship range of a fixed VHF radio such as the RD68 with a masthead antenna will be approximately 20 Km (12 miles). This will increase as height above sea level increases, or if the other radio user's antenna is at a greater height - note that the range between the yacht with the antenna mounted on a 9 M (30 Ft) mast and the shore station increases to 46-53 Km (29-33 Miles).

### 5.3 Frequency of channels

Channel Designators			USA Rx	Channel Designators			USA Rx
	Tx	INT Rx			Tx	INT Rx	
0	156.000	156.000	156.000				
60	156.025	160.625	156.025	17	156.850	156.850	156.850
01	156.050	160.650	156.050	77	156.875	156.875	156.875
61	156.075	160.675	156.075	18	156.900	161.500	156.900
02	156.100	160.700	156.100	78	156.925	161.525	156.925
62	156.125	160.725	156.125	19	156.950	161.550	156.950
03	156.150	160.750	156.150	79	156.975	161.575	156.975
63	156.175	160.775	156.175	20	157.000	161.600	161.600
04	156.200	160.800	156.200	80	157.025	161.625	157.025
64	156.225	160.825	156.225	21	157.050	161.650	157.050
05	156.250	160.850	156.250	81	157.075	161.675	157.075
65	156.275	160.875	156.275	22	157.100	161.700	157.100
06	156.300	156.300	156.300	82	157.125	161.725	157.125
66	156.325	160.925	156.325	23	157.150	161.750	157.150
07	156.350	160.950	156.350	83	157.175	161.775	157.175
67	156.375	156.375	156.375	24	157.200	161.800	161.800
08	156.400	156.400	156.400	84	157.225	161.825	161.825
68	156.425	156.425	156.425	25	157.250	161.850	161.850
09	156.450	156.450	156.450	85	157.275	161.875	161.875
69	156.475	156.475	156.475	26	157.300	161.900	161.900
10	156.500	156.500	156.500	86	157.325	161.925	161.925
70	156.525	156.525	156.525	27	157.350	161.950	161.950
11	156.550	156.550	156.550	87	157.375	157.375	157.375
71	156.575	156.575	156.575	28	157.400	162.000	162.000
12	156.600	156.600	156.600	88	157.425	157.425	157.425
72	156.625	156.625	156.625	29	-	-	157.450
13	156.650	156.650	156.650	89	-	-	157.475
73	156.675	156.675	156.675	WX01	-	-	162.550
14	156.700	156.700	156.700	WX02	-	-	162.400
74	156.725	156.725	156.725	WX03	-	-	162.475
15	156.750	156.750	156.750	WX04	-	-	162.425
75	-	156.775	156.775	WX05	-	-	162.450
16	156.800	156.800	156.800	WX06	-	-	162.500
76	-	156.825	156.825	WX07	-	-	162.525
				WX08	-	-	161.650
				WX09	-	-	161.775
				WX10	-	-	163.275

The following channels may be fitted to your radio. These are only licensed for use in the countries indicated. No attempt should be made to use them in any other country.

Designation	Tx	Rx	Country
M	157.850	157.850	UK
M2	161.425	161.425	UK
31	157.550	161.150	Holland/Belgium
96	162.425	162.425	Belgium
L1/1L	155.500	155.500	Scandinavia
L2/2L	155.525	155.525	Scandinavia
L3/3L	155.650	155.650	Scandinavia (not Denmark)
F1/1F	155.625	155.625	Scandinavia
F2/2F	155.775	155.775	Scandinavia
F3/3F	155.825	155.825	Scandinavia

**NOTE** Ch 0 will only be made available in the UK to Coastguard users with written authorisation.

Channel 70 is the designated Digital Selected Calling (DSC) channel and may not be used for voice transmissions.

## 5.4 Fault finding

Symptom	Possible Cause	Remedy
Unit will not switch on	* Faulty connection to power * Fuse has blown	* Check power connection * Replace fuse and check power supply current
Scan or Memory Scan is locking on a channel without a signal	* Noise on the channel is holding the scan	* Increase squelch level * Inhibit channel from scan (see section 2.11.1)
Dual Watch not being entered	* Priority channel selected * Handset off cradle	* Select a working channel * Replace handset
Cannot change channel	* Dual Watch (D/W) engaged	* Exit Dual Watch
Certain channels are not obtainable	* Some channels are restricted and not programmed depending on country of purchase	* Consult your national authority for permitted channels in your region
Will not transmit	* Scanning or D/W function active	* Exit D/W or Scan
Will not transmit on 25W but OK on 1W	* Low voltage when full transmitting current is drawn * Some channels are restricted to low power transmission only	* Check power supply * Consult your national authority
Transmissions persistently weak/display flashes <b>ANT</b>	* Damaged antenna * Antenna cable broken * Poor contact	* Replace antenna * Replace cable * Check antenna sockets & through deck connector

These simple checks should be carried out before seeking technical assistance and may save time and expense. Before contacting your servicing agent please obtain the radio's serial number. The software iteration should also be quoted - this is shown in the large digits on the display for 2 seconds after the radio is turned on and should be written in the box below for future reference.

## 5.5 Optional accessories

The following accessories are available from your nearest Simrad agent. Please quote the correct part number when ordering -

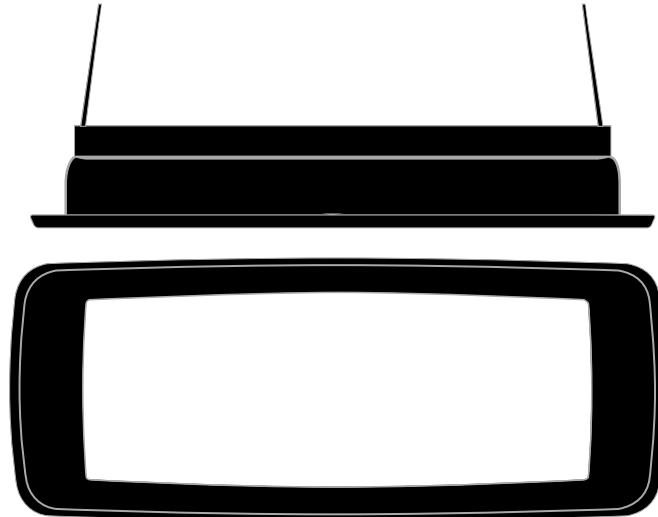

**FMB100BK**  
*Flush Mount Kit*

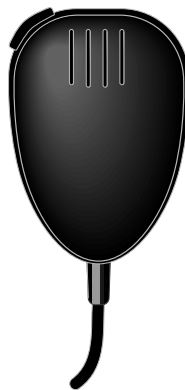

**FTM5-SIM**  
*Spare fistmike*

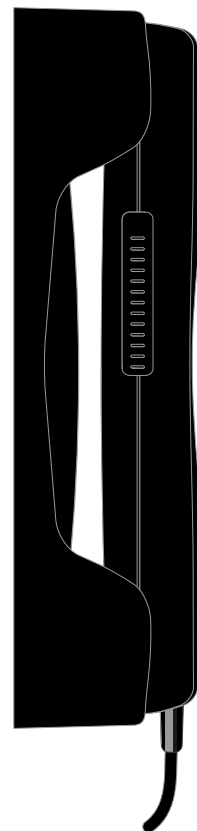

**THS4-SIM**  
*Spare telephone handset*

## 5.6 Technical specification

Power Supply	12v DC (10.8v - 15.5v DC)
Channel Capability	55 international channels
	1-28, 60-88 simplex & semi-duplex
	UK : includes M (previously 37) and M2
	USA : includes 0, 29, 89, 75, 76, Wx1-10 receive only.
	Scandinavia : leisure or fishing channels as appropriate.
	Canada : Canadian and USA channels.
Private Channels	Up to 16 private channels*
External Speaker Impedance	8Ω

\* Contact local Simrad Technical Dealer for further details of channel programming etc.

### Transmit

Frequency Range	155-163Mhz
Power Output	1 watt or 25 watts
Current Consumption	5.5A (25 watts)
	1.3A (1 watt)
Harmonic and Spurious Emissions	< 0.25μW
Hum / Noise	< -40dB
Modulation	±5kHz

### Receive

Audio Output Power	6 watts
Current Consumption	600mA (Full Volume, illumination on)
	220mA (Fully Squelched, illumination off)
Sensitivity	< 0.5μV emf for 20 dB SINAD
Harmonic and Spurious Emissions	< -2nW
Hum / Noise	< -40dB
Adjacent Channel Selectivity	70dB
Intermodulation Rejection	70dB

### Environmental

VHF Radio	Waterproof to IP66 when flush mounted
Fistmike / Telephone Handset	Waterproof to IP67

## 5.7 Dimensions

### RD68 Unit -

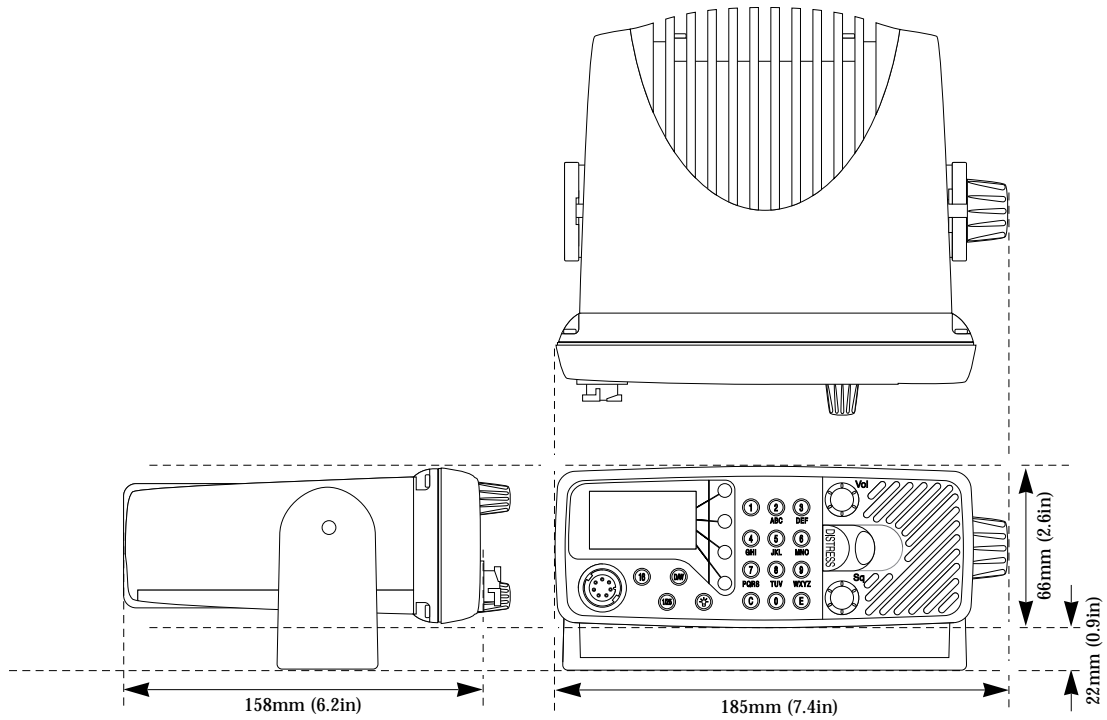

### FTM5 Fismike -

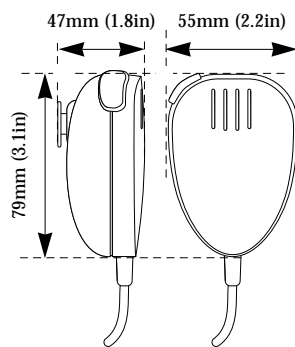

### THS4 Telephone handset -

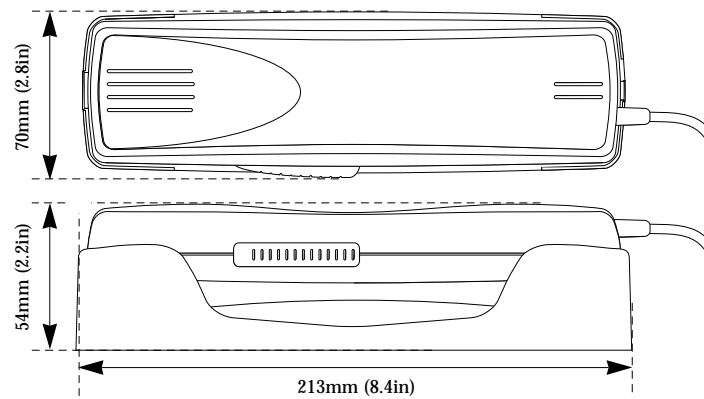

## 5.8 Service & warranty

Your radio should seldom need servicing, although it will benefit from an application of silicone or Teflon grease to the antenna and mic sockets each season. The equipment should be regularly checked by making routine calls to other stations. On an annual basis, test the Distress Alert button by pressing it ONCE. This will display the Distress Alert screen and ensure that the button is functioning. Press **C** to return to the main screen - **DO NOT HOLD DOWN THE DISTRESS BUTTON.**

The unit is guaranteed for 2 years from date of retail sale. If it is necessary to have the unit repaired, return it carriage prepaid to the agent in the country of purchase with a copy of the receipted invoice showing the date of purchase. Where possible, return all the components unless you are certain that you have located the source of the fault. If the original box is not available, ensure that it is well cushioned in packing; the rigours of freight handling can be very different from the loads encountered in the marine environment for which the unit is designed.

For Worldwide Warranty details, please refer to the Warranty Card supplied with this unit.



## DECLARATION OF CONFORMITY

The following product complies with the requirements of EU Directive 1999/5/EC (Radio Equipment and Telecommunications Terminal Equipment) and satisfies all the technical regulations applicable. The assessment has been carried out in accordance with *Annex IV* of the above Directive.

<b>Product:</b>	Simrad RD68W
-----------------	--------------

<b>Notified Body Consulted:</b>	DERA Fraser	<b>Number:</b>	0191
---------------------------------	-------------	----------------	------

The product has been tested to the following Standards:

<b>Article 3(1)(a):</b>	ETS300 828 ERM; EMC for radio telephone transmitters and receivers for the maritime mobile service operating in the VHF bands
<b>Test Report No.:</b>	EMC036
<b>Article 3(1)(b):</b>	EN301 025 ERM; Technical characteristics and methods of measurement for VHF radiotelephone equipment for general communications and associated equipment for Class "D" Digital Selective Calling
<b>Test Report No.:</b>	
<b>Article 3(2):</b>	EN301 025 ERM; Technical characteristics and methods of measurement for VHF radiotelephone equipment for general communications and associated equipment for Class "D" Digital Selective Calling
<b>Test Report No.:</b>	
<b>Article 3(3)(e):</b>	
<b>Test Report No.:</b>	

Signed on behalf of Simrad Navico Ltd -

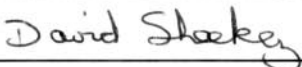
<b>Signed:</b>	
<b>Name:</b>	David Sheekey
<b>Title:</b>	Product Manager - Radio
<b>Date:</b>	19 <sup>th</sup> June 2000

The attention of the purchaser, installer, or user is drawn to special measures and limitations to use which must be observed when the product is taken into service to maintain compliance with the above directives. Details of these special measures and limitations to use are contained in the appropriate product manuals.

QQA150/2 19.06.2000





---

**Manufacturer:**

Simrad Navico  
Star Lane, Margate  
Kent CT9 4NP  
United Kingdom

Telephone: +44 (0) 1843 290290

Telefax: +44 (0) 1843 290471

E-Mail: [sales@simrad-navico.co.uk](mailto:sales@simrad-navico.co.uk)